



# **DAGGER 100**

**Plasma Cutting and Marking System**

User's Manual - Part Number 718100 Rev C  
05/16/2011

This information is subject to the controls of the Export Administration Regulations [EAR]. This information shall not be provided to non-U.S. persons or transferred by any means to any location outside the United States contrary to the requirements of the EAR.

**REVISION**

**C**

**REVISION HISTORY**

Rev	ECO#	Author	Date	Description of Change
A		TDS	04/27/2010	As released
B		TDS	05/28/2010	<ul style="list-style-type: none"> <li>• Updated sections to reflect CE unit requirements</li> <li>• Cut Chart updates</li> </ul>
C		JLW	05/16/2011	<ul style="list-style-type: none"> <li>• Changed voltage divider board part number and description</li> <li>• Added duty cycle limits for expanded metal cutting</li> <li>• Updated consumable part numbers</li> <li>• Updated error codes</li> <li>• Added caution concerning keeping torch consumables mating surfaces clean</li> </ul>

This documentation may not be copied, photocopied, reproduced, translated, or reduced to any electronic medium or machine-readable format without explicit written permission from Kaliburn.

4130 Carolina Commerce Parkway  
Ladson, SC 29456 USA  
(843) 695-4000 - Phone  
(843) 659-4001 - Fax  
[www.kaliburn.net](http://www.kaliburn.net)

## **Limited Warranty**

KALIBURN expressly warrants that this product shall be free from defects in materials and workmanship, under proper and normal use for the intended function of such equipment, for a period of one (1) year for the Dagger100 torch and leads and three (3) years for the Dagger100 power supply. This product is intended for commercial use and is not intended for personal, family, or household purposes. There are no warranties that extend beyond the description on the face hereof. **All other warranties, either expressed or implied, including any implied warranty of merchantability or fitness for any particular purpose, are expressly excluded.**

If this product or any component thereof is determined to be defective in manufacture, KALIBURN will repair or replace the defective component or product. The buyer's remedies are limited to the return of the product for repair or replacement of any non-conforming product or part at the sole discretion of KALIBURN. No freight charges of any kind are covered under this warranty. All returned goods shall be at the buyer's risk and expense. Beyond this remedy, KALIBURN will not be responsible for any special, incidental or consequential damages or injury to the person or property of anyone by reason of any defect in any equipment sold hereunder.

**This warranty will be considered void if torches or torch consumables manufactured by anyone other than KALIBURN are incorporated into this product.**

## **Returned Goods Procedure**

KALIBURN utilizes a returned goods procedure that must be followed before returning any items for repair, replacement, or restocking. This means that a returned goods authorization number must be obtained prior to shipment to KALIBURN. It will be necessary for the customer to provide a description, along with the stock number and serial number, if applicable, of the item to be returned. In no case will KALIBURN accept a returned shipment without the proper returned goods authorization number.

For shipments inside the U.S., parts must be returned to KALIBURN within 30 days of the invoice date to be considered for credit. For shipments outside the U.S., parts must be returned within 60 days of the invoice date to be considered for credit.

# Table of Contents

<b>Section 1 Safety</b> .....	1-1
General Precautions .....	1-1
Ultraviolet Radiation Protection .....	1-1
Noise Protection .....	1-1
Toxic Fume Prevention .....	1-2
Electric Shock Prevention .....	1-2
Fire Prevention .....	1-3
Explosion Prevention .....	1-4
Health Support Equipment .....	1-5
Safety Standards Booklet Index .....	1-5
<b>Section 2 Specifications</b> .....	2-1
System Description .....	2-1
System Components .....	2-1
Power Supply Specifications .....	2-2
Gas Supply Specifications .....	2-3
Mechanized Torch Specifications .....	2-4
Symbols and Markings.....	2-5
Airborne Noise Emissions .....	2-5
<b>Section 3 Installation</b> .....	3-1
Initial Inspection.....	3-1
Power Supply Installation.....	3-1
Mechanized Torch Installation.....	3-1
Primary Power Connection.....	3-2
Power Supply Output Connections .....	3-4
Mechanized Torch Connections.....	3-7
Gas Input Connections.....	3-8
Interface Connections.....	3-9
<b>Section 4 Operation</b> .....	4-1
Power Supply Controls and status Indicators.....	4-1
Operating Modes .....	4-3
Mechanized Torch Consumable Selection .....	4-4
Installing the Mechanized Torch Consumables .....	4-5
Removing the Torch Consumables .....	4-6
Making a Cut or Mark .....	4-8
Cut Quality .....	4-9
Inspection of Consumable Parts .....	4-10
Cutting Charts .....	4-11
<b>Section 5 Maintenance and Troubleshooting</b> .....	5-1
Daily Procedures.....	5-1
Monthly Procedures.....	5-2
Trouble Shooting .....	5-3
<b>Section 6 Parts List</b> .....	6-1
Power Supply.....	6-1
Mechanized Torch Assembly.....	6-4
Leads Assemblies .....	6-4
Consumable Spare Parts Kit.....	6-5
<b>Appendix A Electromagnetic Compatibility (EMC)</b> .....	A-1
Background.....	A-1
Installation and Use.....	A-1
Assessment of Area .....	A-2
Methods of Reducing Emissions .....	A-2

# Section 1 Safety

## General Precautions

Whereas plasma cutting has been used safely for years, it does require certain precautions to ensure the safety of the operator and other people around the equipment. The following safety information must be provided to each person who will operate, observe, perform maintenance, or work in close proximity to this piece of equipment.

Installation, operation, and repairs made to the Dagger system should only be performed by qualified personnel. The Dagger system makes use of both A.C. and D.C. circuitry for operation. **Fatal shock hazard does exist. Exercise extreme caution while working on the system. Safety decals On the Dagger100 power supply should not to be removed.**

## Ultraviolet Radiation Protection



Plasma cutting produces ultraviolet radiation similar to a welding arc. This ultraviolet radiation can cause skin and eye burns. For this reason, it is essential that proper protection be worn. The eyes are best protected by using safety glasses or a welding helmet with an AWS No. 12 shade or ISO 4850 No. 13 shade, which provides protection up to 400 amperes. All exposed skin areas should be covered with flame-retardant clothing. The cutting area should also be prepared in such a way that ultraviolet light does not reflect. Walls and other surfaces should be painted with dark colors to reduce reflected light. Protective screens or curtains should be installed to protect additional workers in the area from ultraviolet radiation.

## Noise Protection



The Dagger system generates high noise levels while cutting. Depending on the size of the cutting area, distance from the cutting torch, and arc current cutting level, acceptable noise levels may be exceeded. Proper ear protection should be used as defined by local or national codes. See Section 2 for noise emission levels.

This information is subject to the controls of the Export Administration Regulations [EAR]. This information shall not be provided to non-U.S. persons or transferred by any means to any location outside the United States contrary to the requirements of the EAR.

## Toxic Fume Prevention



Care should be taken to ensure adequate ventilation in the cutting area. Some materials give off toxic fumes that can be harmful or fatal to people in the vicinity of the cutting area. Also, some solvents decompose and form harmful gases when exposed to ultraviolet radiation. These solvents should be removed from the area prior to cutting. Galvanized metal can produce harmful gases during the cutting process. Ensure proper ventilation and use breathing equipment when cutting these materials.

Certain metals coated with or containing lead, cadmium, zinc, beryllium, and mercury produce harmful toxins. Do not cut these metals unless all people subjected to the fumes wear proper air breathing equipment.

## Electric Shock Prevention



The Dagger system uses high open circuit voltages that can be fatal. Extreme care should be used when operating or performing maintenance on the system. Only qualified personnel should service the Dagger system. Observe the following guidelines to protect against electric shock:

- A wall-mounted disconnect switch should be installed and fused according to local and national electrical codes. The disconnect switch should be located as close as possible to the power supply so it can be turned off in case of an emergency.
- The primary power cord should have a 600 volt minimum rating in order to protect the operator. In addition, it should be sized according to local and national electrical codes. Inspect the primary power cord frequently. Never operate the Dagger system if the power cord is damaged in any way.
- Make sure the primary power ground wire is connected at the input power ground location on the Dagger power supply. Make sure the connection is securely tightened.
- Make sure the positive output (work ground) of the Dagger power supply is connected to a bare metal area on the cutting table. A driven ground rod should be placed no further than five feet from this connection. Make sure this ground point on the cutting table is used as the star ground point for all other ground connections.
- Inspect the torch leads frequently. Never use the system if the leads are damaged in any way.

This information is subject to the controls of the Export Administration Regulations [EAR]. This information shall not be provided to non-U.S. persons or transferred by any means to any location outside the United States contrary to the requirements of the EAR.

- 
- Do not stand in wet, damp areas when operating or performing maintenance on the system.
  - Wear insulated gloves and shoes while operating or performing maintenance on the system.
  - Make sure the system is switched off at the wall disconnect before servicing the power supply or torch.
  - Never change torch consumable parts unless main power to the Dagger system is switched off at the power supply or wall disconnect.
  - Do not attempt to remove any parts from beneath the torch when cutting. Remember that the workpiece forms the current path back to the power supply.
  - Never bypass the safety interlock devices.
  - Before removing any of the Dagger covers, switch the system off at the wall disconnect. Wait at least five (5) minutes before removing any cover. This will give the capacitors inside the unit time to discharge.
  - Never operate the Dagger system without all of the covers in place.
  - Preventive maintenance should be performed daily to avoid possible safety hazards.

## Fire Prevention



When using the Dagger system, it is necessary to exercise good judgment. While cutting, the arc produces sparks that could cause a fire if they fall on flammable materials. Make sure that all flammable materials are a suitable distance away from the cutting area. All flammable liquids should be at least 40 feet away from the cutting area, preferably stored in a metal cabinet. Plasma cutting should never be attempted on containers that contain flammable materials. Make sure that fire extinguishers are readily accessible in the cutting area.

---

## Explosion Prevention



The Dagger system uses compressed gases. Use proper techniques when handling compressed gas cylinders and other compressed gas equipment. Observe the following guidelines to protect against explosion:

- Never operate the Dagger system in the presence of explosive gases or other explosive materials.
- Never cut pressurized cylinders or any closed container.
- When using a water table and cutting aluminum under water or with water touching the underside of the aluminum plate, hydrogen gas is produced. This hydrogen gas may collect under the plate and explode during the cutting process. Make sure the water table is properly aerated to help prevent the accumulation of hydrogen gas.
- Handle all gas cylinders in accordance with safety standards published by the U.S. Compressed Gas Association (CGA), American Welding Society (AWS), Canadian Standards Association (CSA), or other local or national codes.
- Compressed gas cylinders should be maintained properly. Never attempt to use a cylinder that is leaking, cracked, or has other signs of physical damage.
- All gas cylinders should be secured to a wall or rack to prevent accidental knock over.
- If a compressed gas cylinder is not being used, replace the protective valve cover.
- Never attempt to repair compressed gas cylinders.
- Keep compressed gas cylinders away from intense heat, sparks, or flames.
- Clear the compressed gas cylinder connection point by opening the valve momentarily prior to installing a regulator.
- Never lubricate compressed gas cylinder valves or pressure regulators with any type of oil or grease.
- Never use a compressed gas cylinder or pressure regulator for any purpose other than which it is intended.
- Never use a pressure regulator for any gas other than which it is intended.
- Never use a pressure regulator that is leaking or has other signs of physical damage.
- Never use any gas hose that is leaking or has other signs of physical damage.

---

## Health Support Equipment



The Dagger system creates electric and magnetic fields that may interfere with certain types of health support equipment, such as pacemakers. Any person who uses a pacemaker or similar item should consult a doctor before operating, observing, maintaining, or servicing the system. Observe the following guidelines to minimize exposure to these electric and magnetic fields:

- Stay as far away from the Dagger power supply, torch, and torch leads as possible.
- Route the torch leads as close as possible to the work ground cable.
- Never place your body between the torch leads and work ground cable. Keep the work ground cable and the torch leads on the same side of your body.
- Never stand in the center of a coiled up set of torch leads or work ground cable.

## Safety Standards Booklet Index

For further information concerning safety practices to be exercised with plasma arc cutting equipment, please refer to the following publications:

1. AWS Standard AWN, *Arc Welding and Cutting Noise*, obtainable from the American Welding Society, 550 NW LeJeune Road, Miami, FL 33126.
2. AWS Standard C5.2, *Recommended Practices for Plasma Arc Cutting*, obtainable from the American Welding Society, 550 NW LeJeune Road, Miami, FL 33126.
3. AWS Standard FSW, *Fire Safety in Welding and Cutting*, obtainable from the American Welding Society, 550 NW LeJeune Road, Miami, FL 33126.
4. AWS Standard F4.1, *Recommended Safe Practices for Preparation for Welding and Cutting of Containers and Piping*, obtainable from the American Welding Society, 550 NW LeJeune Road, Miami, FL 33126.
5. AWS Standard ULR, *Ultraviolet Reflectance of Paint*, obtainable from the American Welding Society, 550 NW LeJeune Road, Miami, FL 33126.
6. AWS / ANSI Standard Z49.1, *Safety in Welding, Cutting, and Allied Processes*, obtainable from the American Welding Society, 550 NW LeJeune Road, Miami, FL 33126.
7. ANSI Standard Z41.1, *Standard For Men's Safety-Toe Footwear*, obtainable from the American National Standards Institute, 11 West 42nd Street, New York, NY 10036.

This information is subject to the controls of the Export Administration Regulations [EAR]. This information shall not be provided to non-U.S. persons or transferred by any means to any location outside the United States contrary to the requirements of the EAR.

8. ANSI Standard Z49.2, *Fire Prevention in the Use of Cutting and Welding Processes*, obtainable from the American National Standards Institute, 11 West 42nd Street, New York, NY 10036.
9. ANSI Standard Z87.1, *Safe Practices For Occupation and Educational Eye and Face Protection*, obtainable from the American National Standards Institute, 11 West 42nd Street, New York, NY 10036.
10. ANSI Standard Z88.2, *Respiratory Protection*, obtainable from the American National Standards Institute, 11 West 42nd Street, New York, NY 10036.
11. OSHA Standard 29CFR 1910.252, *Safety and Health Standards*, obtainable from the U.S. Government Printing Office, Washington, D.C. 20402.
12. NFPA Standard 51, *Oxygen - Fuel Gas Systems for Welding, Cutting, and Allied Processes*, obtainable from the National Fire Protection Association, 1 Batterymarch Park, Quincy, MA 02269.
13. NFPA Standard 51B, *Cutting and Welding Processes*, obtainable from the National Fire Protection Association, 1 Batterymarch Park, Quincy, MA 02269.
14. NFPA Standard 70, *National Electrical Code*, obtainable from the National Fire Protection Association, 1 Batterymarch Park, Quincy, MA 02269.
15. CGA booklet P-1, *Safe Handling of Compressed Gases in Containers*, obtainable from the Compressed Gas Association, 1725 Jefferson Davis Highway, Suite 1004, Arlington, VA 22202.
16. CGA booklet P-14, *Accident Prevention in Oxygen-Rich and Oxygen-Deficient Atmospheres*, obtainable from the Compressed Gas Association, 1725 Jefferson Davis Highway, Suite 1004, Arlington, VA 22202.
17. CGA booklet TB-3, *Hose Line Flashback Arrestors*, obtainable from the Compressed Gas Association, 1725 Jefferson Davis Highway, Suite 1004, Arlington, VA 22202.
18. CSA Standard W117.2, *Safety in Welding, Cutting, and Allied Processes*, obtainable from Canadian Standards Association, 178 Rexdale Boulevard, Toronto, Ontario M9W 1R3, Canada.
19. Canadian Electrical Code Part 1, *Safety Standard for Electrical Installations*, obtainable from the Canadian Standards Association, 178 Rexdale Boulevard, Toronto, Ontario M9W 1R3, Canada.

This information is subject to the controls of the Export Administration Regulations [EAR]. This information shall not be provided to non-U.S. persons or transferred by any means to any location outside the United States contrary to the requirements of the EAR.

# Section 2 Specifications

## System Description

The Dagger100 is a versatile, 100 amp, variable duty cycle plasma cutting and marking system. It utilizes a single gas torch that is capable of cutting gauge to 1½ inch (38 mm) thick material. Recommended pierce capacity of the Dagger100 is ½ inch (13 mm) with a maximum piercing capacity of ¾ inch (19mm). The Dagger100 can severe material up to 1¾ inch with an edge start at slow speeds. The Dagger100 is equipped with a quick disconnect torch lead. This feature allows the torch lead connections to be completed with one connection on the front of the power supply. The Dagger100 power supply utilizes a universal input and will operate on AC voltages from 200V – 600V, 3PH. The temperature controlled fan feature allows the Dagger system to maintain proper operating temperature. The fans automatically turn on when the system reaches a specified temperature.

The Dagger100 uses four nozzle sizes (40, 60, 80, and 100) that are available to cut throughout the material thickness range. The Dagger100 also has 3 modes of operation, which provide the capability for cutting and marking all types of material. A digital current thumbwheel provides repeatable current settings, which results in repeatable cuts. These features alone provide durability, cost effective operation and excellent cut quality. In addition, the use of air as the plasma and cooling gases enhances the cost effectiveness.

The degree of protection provided by the Dagger100 system is IP21S, and as such is intended only for indoor use. It is not suitable for use in rain or snow.

## System Components

The Dagger100 consists of the following components:

### Standard Components

- Power Supply
- Mechanized Torch and Lead Assembly
- System Manual
- Consumable Spare Parts Kit (see Section 6 for details)

This information is subject to the controls of the Export Administration Regulations [EAR]. This information shall not be provided to non-U.S. persons or transferred by any means to any location outside the United States contrary to the requirements of the EAR.

## Power Supply Specifications

<b>Stock Number</b>		
		980000
<b>Input Current at Rated Output</b>		
200-208 VAC		52 amps
230-240 VAC		45 amps
380-415 VAC		27 amps
480 VAC 3PH		22 amps
600 VAC 3PH		23 amps
<b>Open Circuit Voltage</b>		
		300VDC
<b>Arc Striking Voltage</b>		
		5.75kV
<b>Output Current</b> ( <i>drooping characteristic</i> )		
		20-100 amps
<b>Standard Output Voltage</b>		
		160VDC
<b>Ambient Temperature</b>		
		104° F (40° C)
<b>Duty Cycle</b> ( <i>% percentage of time, during a 10 minute period, that the power supply can cut</i> )		
200-208 VAC, 3Ø, 60Hz	80 amps	100%
	100 amps	60%
230-240 VAC, 3Ø, 60Hz	85 amps	100%
	100 amps	70%
380-415 VAC, 3Ø, 50/60Hz	89 amps	100%
	100 amps	79%
480 VAC, 3Ø, 60Hz	90 amps	100%
	100 amps	80%
600 VAC, 3Ø, 60Hz	90 amps	100%
	100 amps	80%
<b>Dimensions</b>		
Width		12.5 in (317.5 mm)
Height		18.88 in (479.43 mm)
Length		23.12 in (587.24 mm)
<b>Weight</b>		
		105 lb ( 47.6 kg)

This information is subject to the controls of the Export Administration Regulations [EAR]. This information shall not be provided to non-U.S. persons or transferred by any means to any location outside the United States contrary to the requirements of the EAR.

## Gas Supply Requirements

Compressed air must be clean, dry, and oil-free and may be supplied from compressed cylinders or from an air compressor. Be aware that shop air systems are prone to oil and moisture contamination. If shop air is used, it must be cleaned to ISO 8573.1: Class 1.4.1. Specify dry air when using compressed cylinders. Breathing quality air contains moisture and must not be used. 3/8" (inside diameter) hoses are required for all inlet gas connections. **Quick-connect fittings must not be used.**

Quality	Dry, oil-free air cleaned to ISO standard 8573.1: Class 1.4.1
Flow Rate	460 scfh (13025.75liters/hour)
Inlet Pressure	90 psig (6.2 bar)

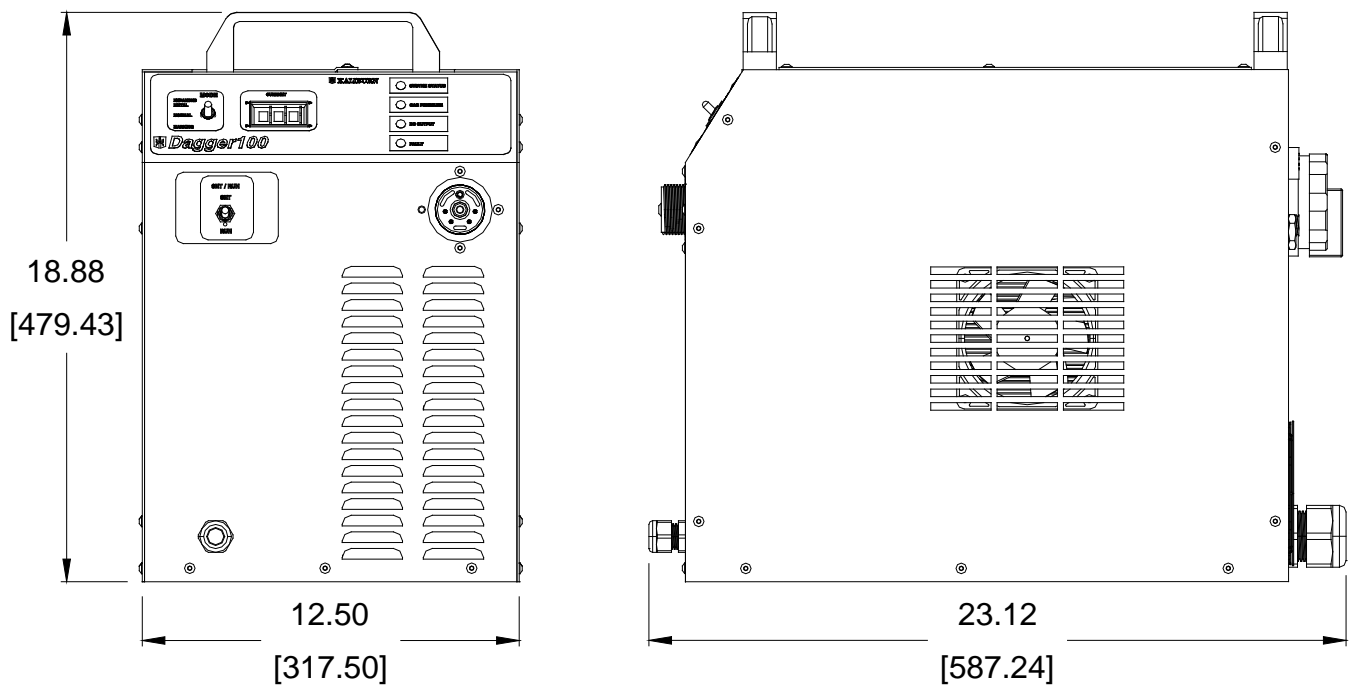

This information is subject to the controls of the Export Administration Regulations [EAR]. This information shall not be provided to non-U.S. persons or transferred by any means to any location outside the United States contrary to the requirements of the EAR.

## Mechanized Torch Specifications

Stock Number	
25 ft(7.5m) lead	980290-25
35 ft(10.7m) lead	980290-35
50ft(15.2m) lead	980290-50
Weight	
25 ft(7.5m) lead	8 lb ( 3.6 kg)
35 ft(10.7m) lead	11.3 lb ( 5.1kg)
50ft(15.2m) lead	15 lb ( 6.8 kg)



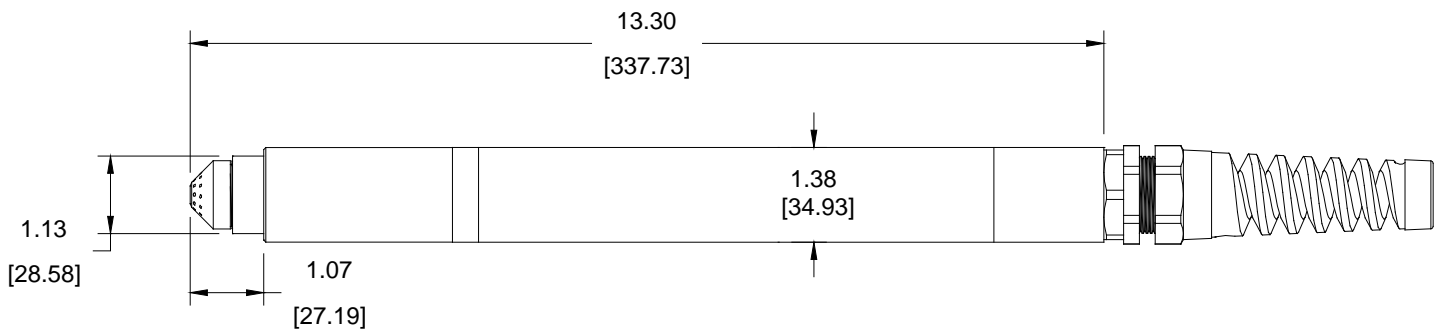





***The Dagger100 mechanized torch and lead assembly complies with the requirements of IEC60974-7***

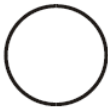

This information is subject to the controls of the Export Administration Regulations [EAR]. This information shall not be provided to non-U.S. persons or transferred by any means to any location outside the United States contrary to the requirements of the EAR.

## Symbols and Markings

### IEC Symbols Used on the Dagger100

	Power is ON		Direct Current (DC)
	Power is OFF		Protective Earth
	Plasma Torch Cutting		Inverter Based power source
	Caution		Power Supply Type of device
	Read Instruction Manual		

## Airborne Noise Emissions

The Dagger100 system generates high noise levels while cutting. Depending on the size of the cutting area, distance from the cutting torch, and arc current cutting level, acceptable noise levels may be exceeded. Proper ear protection should be used as defined by local or national codes. The following chart gives the noise levels generated by the Dagger100 when operating at 100 amps, 120 arc volts. The measurements were made with a sound level meter.

Distance From Torch	A-Weighted Sound Pressure Level	C-Weighted Sound Pressure Level
1 meter horizontal / 1.6 meters above the work piece	98dB	96dB

The maximum noise level is 123 dB at a distance of 2 inches (50.8 mm) from the torch while cutting at 100 amps, 120 arc volts.

This information is subject to the controls of the Export Administration Regulations [EAR]. This information shall not be provided to non-U.S. persons or transferred by any means to any location outside the United States contrary to the requirements of the EAR.

## Section 3 Installation

### Initial Inspection

All systems undergo full testing before being shipped from KALIBURN. In the unlikely event that one of your components is defective or missing, please contact KALIBURN so a replacement item can be sent to you. Also, KALIBURN has taken special care in packaging your Dagger system. If your system was damaged during shipment, you will have to file a claim with the shipping company. Next, it will be necessary to contact KALIBURN so replacement parts can be ordered. If you need additional assistance, please contact KALIBURN.

### Power Supply Installation

The Dagger100 power supply should be lifted by two people or a hoist. In order to prevent damaging the power supply, the power supply should be lifted with both handles while keeping the unit as horizontal as possible. Only hoisting straps approved for the weight of the power supply should be used. The proper location of the power supply will provide dependable service and reduce periodic maintenance time. Choose a location that will provide unrestricted air movement into and out of the power supply. Maintain **at least 10 inches** of space on **all** sides of the unit. The location should subject the power supply to the least amount of dust, dirt, moisture, and corrosive vapors. The surface on which the power supply is located should have a grade of no greater than 15° to eliminate the risk of toppling over. The power supply must be cleaned as often as necessary to prevent the accumulation of metallic dust inside the unit. See Section 2 for power supply dimensions.

### Mechanized Torch Installation

It is recommended that the Dagger100 mechanized torch be installed on a positioner with an arc voltage control capable of maintaining the cutting arc voltage within 1 volt. The positioner must be rigid to ensure cut quality and a torch collision sensor is highly recommended. See Section 2 for the mechanized torch mounting dimensions.

## Primary Power Connection

A primary disconnect switch, switching all ungrounded supply conductors, should be provided for each Dagger power supply. The disconnect switch should be located as close as possible to the power supply so it can be turned off quickly in case of an emergency. **The disconnect switch should be equipped with time delay fuses only.** The magnetic inrush current of the power supply will cause fast acting fuses to blow. The disconnect switch should be sized according to local and national codes. The rating must meet or exceed the continuous rating of the fuses used. See the following chart for recommended fuse sizes:

CSA Model		
3 Phase Input Voltage (VAC)	Input Current at Rated Output (amps)	Recommended Time-Delay Fuse Size (amps)
200-208V	52	80
230-240V	45	80
400V	27	50
480V	22	40
600V	23	40

CE Model		
3 Phase Input Voltage (VAC)	Input Current at Rated Output (amps)	Recommended Time-Delay Fuse Size (amps)
230V	45	80
400V	27	50

Use a type SO (90°C rated) power cable to connect the primary power to the Dagger power supply. The supply cables should have a 600 volt minimum rating and should be sized according to local and national codes. Route the supply cables through the strain relief in the lower rear portion of the power supply and connect the hot lines to the L1(U), L2(V), L3(W) terminals of the line disconnect switch as shown in figure below. Be sure to connect the protective ground (PE) cable to the PE terminal adjacent to the disconnect switch.

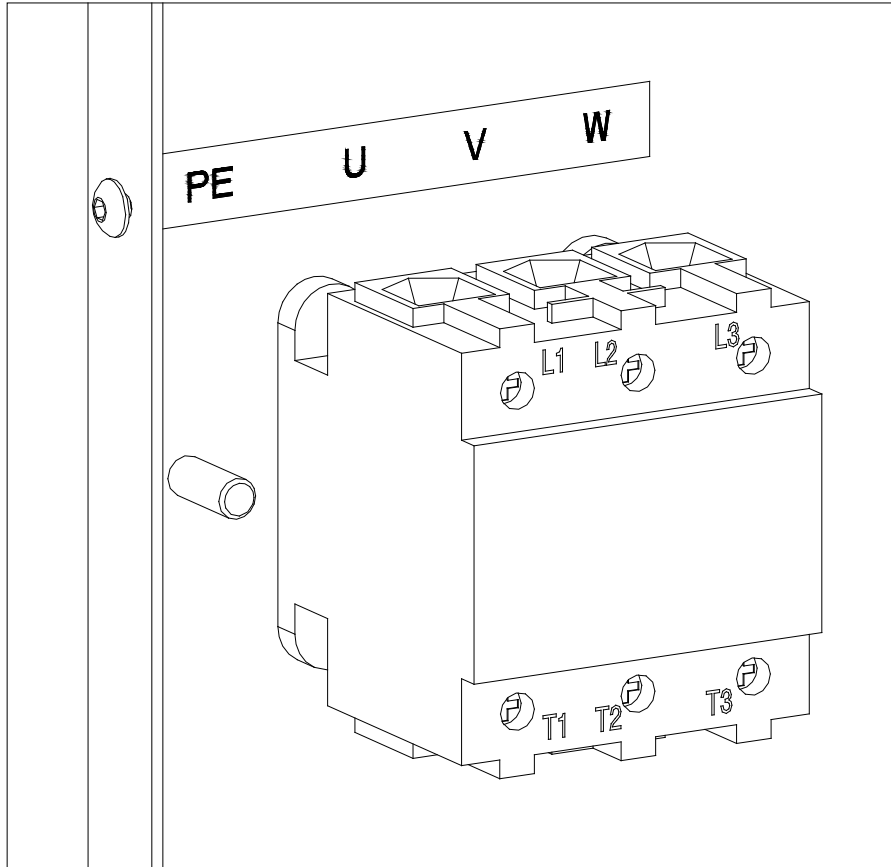

**Input Power Connections**

This information is subject to the controls of the Export Administration Regulations [EAR]. This information shall not be provided to non-U.S. persons or transferred by any means to any location outside the United States contrary to the requirements of the EAR.

## Power Supply Output Connections

Perform the following steps to connect the output of the power supply to the quick disconnect torch lead assembly and the work table.

### Quick Disconnect Torch Lead

**\*\*Note:** Use only the torch specified in this manual. Do not attempt to install any other torch.

1. Make sure the power switch is in the OFF position.
2. Align the torch lead quick disconnect (1) with the connection point (2) located on the front of the power supply. The component's alignment points are designed to insure proper connection. See figure below.

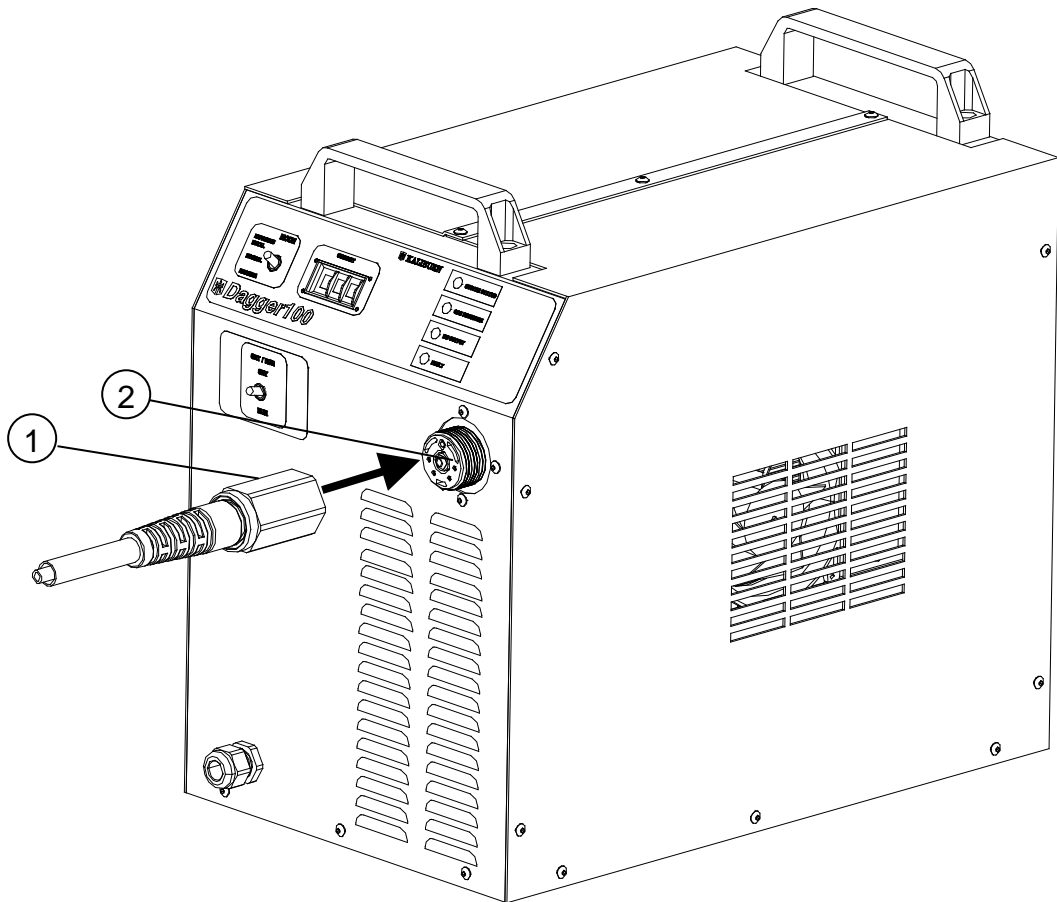

This information is subject to the controls of the Export Administration Regulations [EAR]. This information shall not be provided to non-U.S. persons or transferred by any means to any location outside the United States contrary to the requirements of the EAR.

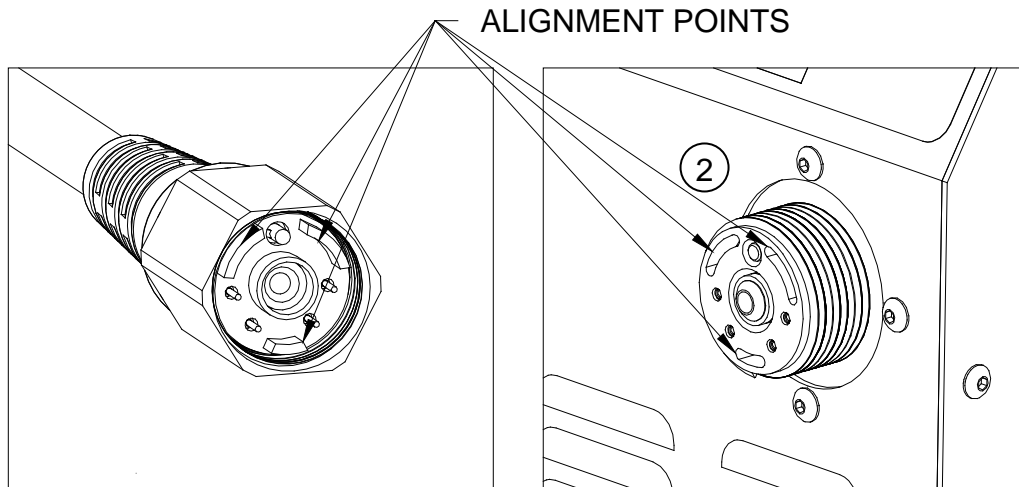

3. Slide the nut over the threaded portion of the connection and tighten. **Be sure to tighten the assembly firmly in order to ensure a good electrical connection and to seal the gas line.**

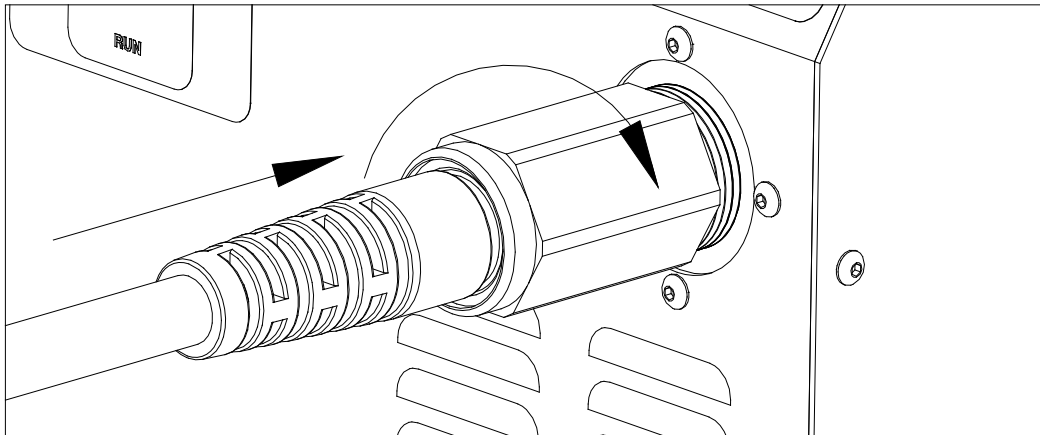

This information is subject to the controls of the Export Administration Regulations [EAR]. This information shall not be provided to non-U.S. persons or transferred by any means to any location outside the United States contrary to the requirements of the EAR.

## Work Ground Lead

1. Route one end of the #6 AWG work ground lead (3) through the strain relief (4) on the front of the power supply and connect it to the Work Ground connector on the base of the power supply.
2. Connect the other end of the work ground lead to the star ground point on the cutting table. The star ground point is generally referred to as the common ground point on the cutting table where all subsystems of the machine are grounded. This point is then connected to a driven earth ground rod that should be as close as possible to the star ground. The ground rod should have no other wires connected to it. The ground rod should be at least 3/4 inch in diameter and should be driven into the earth's permanent moisture layer. The length of the ground rod varies from installation to installation and should be installed according to local and national codes. Refer to the National Electrical Code, Article 250, Section H, Ground Electrode System for additional information.

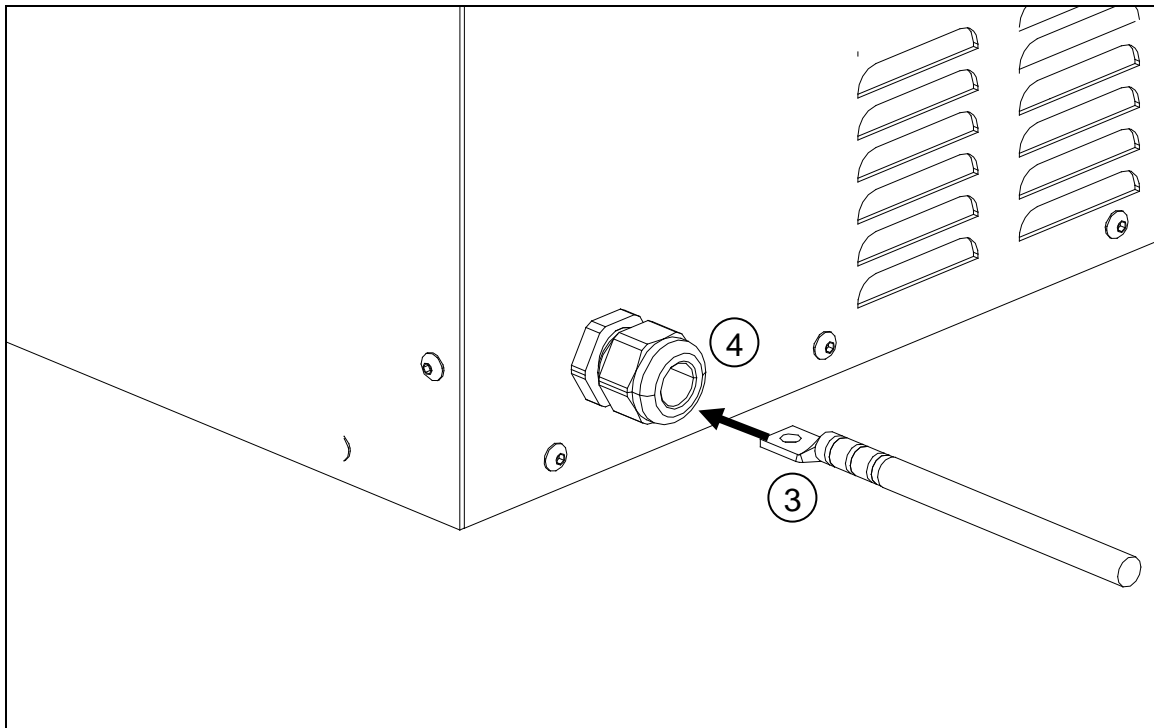

This information is subject to the controls of the Export Administration Regulations [EAR]. This information shall not be provided to non-U.S. persons or transferred by any means to any location outside the United States contrary to the requirements of the EAR.

## Mechanized Torch Connections

Perform the following steps to connect the torch lead assembly to the mechanized torch.

**Note:** *When making hose connections, only tighten the brass fittings enough to make a gas seal. The fittings are subject to damage if over tightened. Also, use two wrenches when tightening the torch fittings to avoid damaging the torch.*

1. Unscrew the torch handle assembly from the torch main body and slide the torch leads through the handle.
2. Attach the pilot arc lead to the torch pilot arc lead. (5)
3. Attach the electrode lead to (6) the electrode fitting on the torch body.
4. Attach the torch switch to the torch switch leads. (7)
5. Slide the handle down over the connections and thread the handle onto the torch body, being careful to avoid cross-threading the handle. When tightening the handle, be sure to turn the handle and not the torch body. This will avoid twisting the torch leads.
6. Tighten the strain relief at the rear of the torch handle.

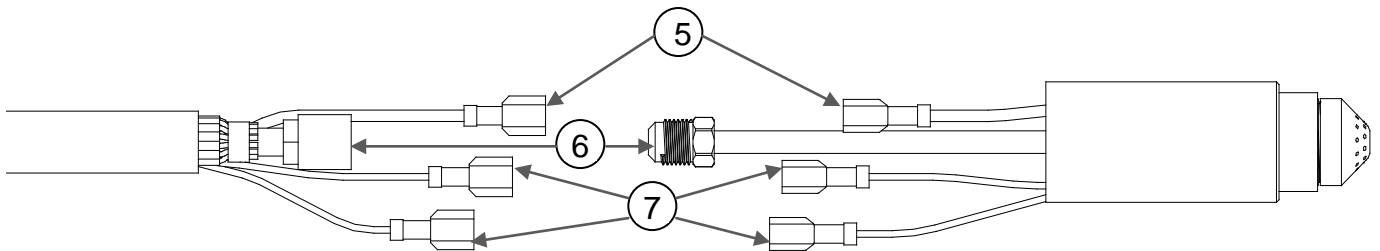

## Gas Input Connections

The Dagger requires clean, dry, oil-free compressed gas for good cut quality, as well as long consumable life. The plasma system is supplied with a regulator-filter (8) to filter the incoming gas supply. Additional filtration may be required if there is moisture, oil, or other contaminants in the gas supply.

The regulator-filter supplied with the Dagger100 should be used with industrial compressed air systems only. It must not be used where the inlet pressure can exceed 150 psi or when the temperature can exceed 125° F. The regulator should be mounted in the vertical position on the rear panel to allow filtered material to drain through the lower exit tube. Some units are equipped with an automatic drain and others have a manual drain. In either case, be sure that contaminants do not accumulate in the filter bowl. The filter element will require periodic replacement, depending on the amount of contamination in the line. Replacement filter elements are available from KALIBURN. Perform the following steps to connect the power supply to the gas supply.

1. Mount the regulator-filter in a vertical position on the rear left side of the power supply.
2. Connect a 3/8" (9.5 mm) minimum inside diameter hose to the inlet port of the regulator-filter. A 1/4" NPT to 3/8" flair fitting and a 3/8" hose barb are included for making connection.
3. Be sure that all gas supply connections are tight. Leaks in the supply can cause poor cut quality.

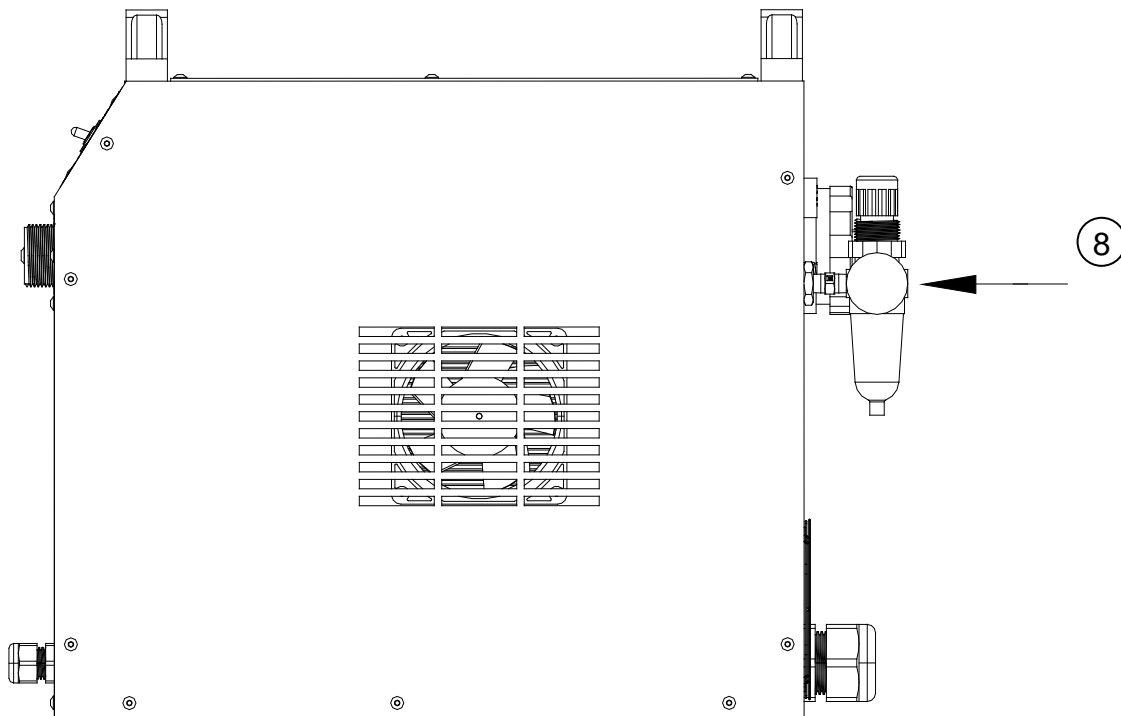

This information is subject to the controls of the Export Administration Regulations [EAR]. This information shall not be provided to non-U.S. persons or transferred by any means to any location outside the United States contrary to the requirements of the EAR.

## Interface Connections

Inputs are available through the machine interface connection. <sup>9</sup> The machine interface connection is located on the rear of the power supply.

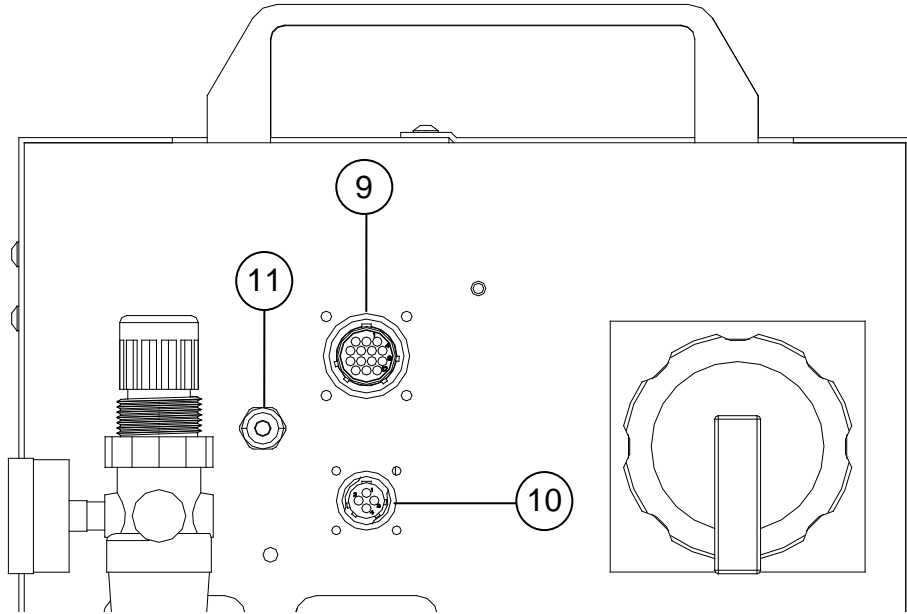

### CNC <sup>9</sup>

Perform the following steps to properly interface the system with a CNC cutting machine. See the system schematic for additional information. The mating plug and associated pins are included for customer connection.

#### Plasma Start Input

The Dagger100 requires a contact closure between P8 pins 3 and 4 to commence the cutting or marking sequence. The sequence is terminated when the contacts are opened. The contacts should be rated for 24VDC - 10mA.

#### Plasma Cut/Mark Input

The Dagger100 requires a contact closure between P8 pins 1 and 2 to put the system in plasma marking mode. Opening the contacts puts the system in cutting mode. The operating mode should be selected prior to applying a start signal. The contacts should be rated for 24VDC - 10mA.

#### Motion Output

The Dagger100 provides a maintained contact closure between P8 pins 12 and 14 as long as a cutting arc is maintained between the torch and the work piece.

This information is subject to the controls of the Export Administration Regulations [EAR]. This information shall not be provided to non-U.S. persons or transferred by any means to any location outside the United States contrary to the requirements of the EAR.

---

## Mechanized Torch Height Control

### Arc Voltage Output (10)

The Dagger100 with the optional Voltage Divider board (Part Number 980610) installed supplies a voltage output signal between pins 1 and 4 of P7. Pin #1 is the PS- signal and Pin #4 is the PS+ signal. The mating plug and associated sockets are included for customer connection.

A 40:1 voltage ratio for use with Inova Height Controls or a 28:1 ratio for use with Smart HC Height Controls can be selected by a jumper on the voltage divider board.

### Clear the Plate Function (11)

In order to utilize the clear the plate (CTP) function, route the end of the CTP lead through the strain relief on the rear of the unit and connect it to the CTP tab on the voltage divider.

Tighten the strain relief after the connection is made.

Route the other end of the CTP, as required, to the mechanized torch (with consumables installed) and connect it to the tab on the retaining cap.

The CTP logic output is provided through pins 2 and 3 of P7. Pin #2 is the Logic+ signal and Pin #3 is the Logic- signal.

## Section 4 Operation

### Power Supply Controls and Status Indicators

The Dagger100 power on/off switch is located in the rear of the power supply. All of the other Dagger100 controls and status indicator lights are located on the front panel of the power supply as shown below. This section describes the function of each control and indicator. See Figure 1 for power switch location and see Figure 2 for front panel control and indicator locations.

#### Power Switch ①

When in the **OFF** position the Dagger100 system will be de-energized and all power removed at the load side of the switch. **Note: The line side of the switch will be electrically hot.**

When in the **ON** position the Dagger100 system will be energized and ready for operation.

#### Mode Switch ②

Used to set the operating mode of the Dagger100.

#### Set/Run Switch ③

In the **Set** mode, the gas solenoid will energize so the gas pressure may be adjusted and will reset specific faults provided the fault has been cleared. In the **Run** mode, the gas solenoid will de-energize and await a start command.

#### Current Thumbwheel ④

Used to set the output current of the Dagger100. The output current can be set in 1 amp increments.

#### System Status Indicator ⑤

After the main power switch has been placed in the **ON** position the system status indicator illuminates green provided no system faults have been detected. The system status indicator will flash on and off when a fault exists and prevent system operation.

#### Gas Pressure Indicator ⑥

Illuminates when there is acceptable gas pressure for torch operation. Remains extinguished when there is low gas pressure.

#### DC Power Indicator ⑦

Illuminates when a start command has been initiated and voltage is present at output terminals of the power supply.

#### Fault Indicator ⑧

Illuminates when an error exists. A blinking pattern will identify the type of error.

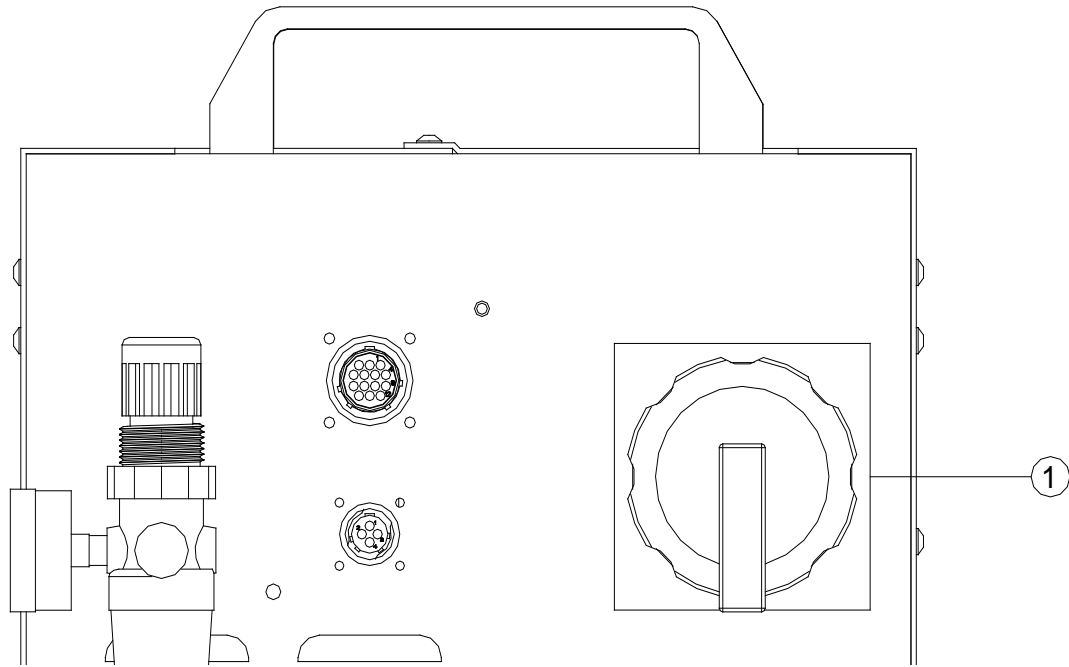

Figure 1

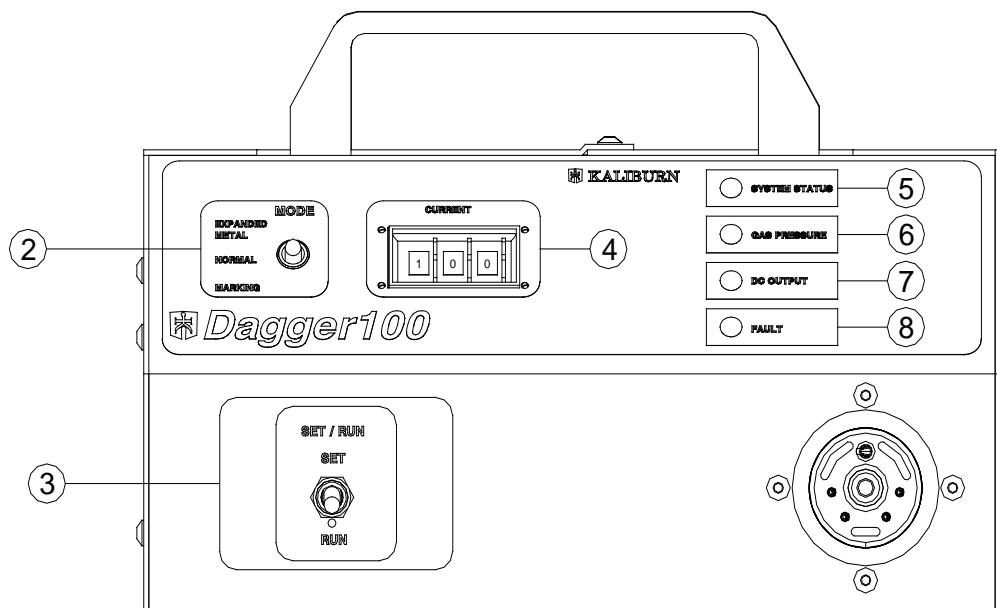

Figure 2

This information is subject to the controls of the Export Administration Regulations [EAR]. This information shall not be provided to non-U.S. persons or transferred by any means to any location outside the United States contrary to the requirements of the EAR.

---

## Operating Modes

The operating mode of the Dagger100 is switch selectable and can either be Normal, Expanded Metal, or Marking. The mode switch is located on the control panel of the power supply. The operating modes are described below. Marking can also be selected through the Machine Interface on the rear of the power supply – see Section 3.

### Normal Cutting Mode

To place the Dagger100 in the normal cutting mode, set the Mode Switch to the normal position. The start signal initiates the following sequence of events:

1. 1.5 second gas preflow.
2. Pilot arc initiation – pilot arc will be maintained for 3 seconds after which if a transferred arc has not been detected, the pilot arc will terminate to minimize nozzle and electrode wear.
3. Transferred arc establishes (cutting arc).
4. X/Y motion signal enabled. There is no motion delay provided by the Dagger100. If motion delay is required, it will have to be programmed into the X/Y Controller.

Removal of the plasma start signal terminates the cutting or marking process, disables the x/y motion signal, and initiates gas postflow. Note: Loss of the cutting arc, even if a plasma start signal is applied, deenergizes the Dagger100 system, disables the x/y machine motion signal, and initiates postflow of gas.

### Expanded Metal Cutting Mode

To place the Dagger100 in the expanded metal cutting mode, set the Mode Switch to the expanded metal position. The starting sequence is the same as that for Normal cutting with the following exceptions. The system reverts to a pilot arc condition for a period of 3 seconds when the transferred arc is lost. The x/y motion signal is enabled as soon as the pilot arc is established and remains enabled until the plasma start signal is removed or the pilot arc times out. The cutting sequence is terminated when the plasma start signal is disabled. The pilot arc circuit is limited in duty cycle and may limit the cut duty depending upon the size of the mesh being cut and duration of the cut.

### Marking Mode

To place the Dagger100 in the marking mode, set the mode switch to the marking position or select marking through the CNC Machine Interface. The starting sequence is the same as that for Normal cutting. However, the current selected via the thumbwheel switch is over-ridden and the power supply regulates the output current to a lower current appropriate for marking.

## Mechanized Torch Consumables

Figure 4-3 shows the different torch consumables

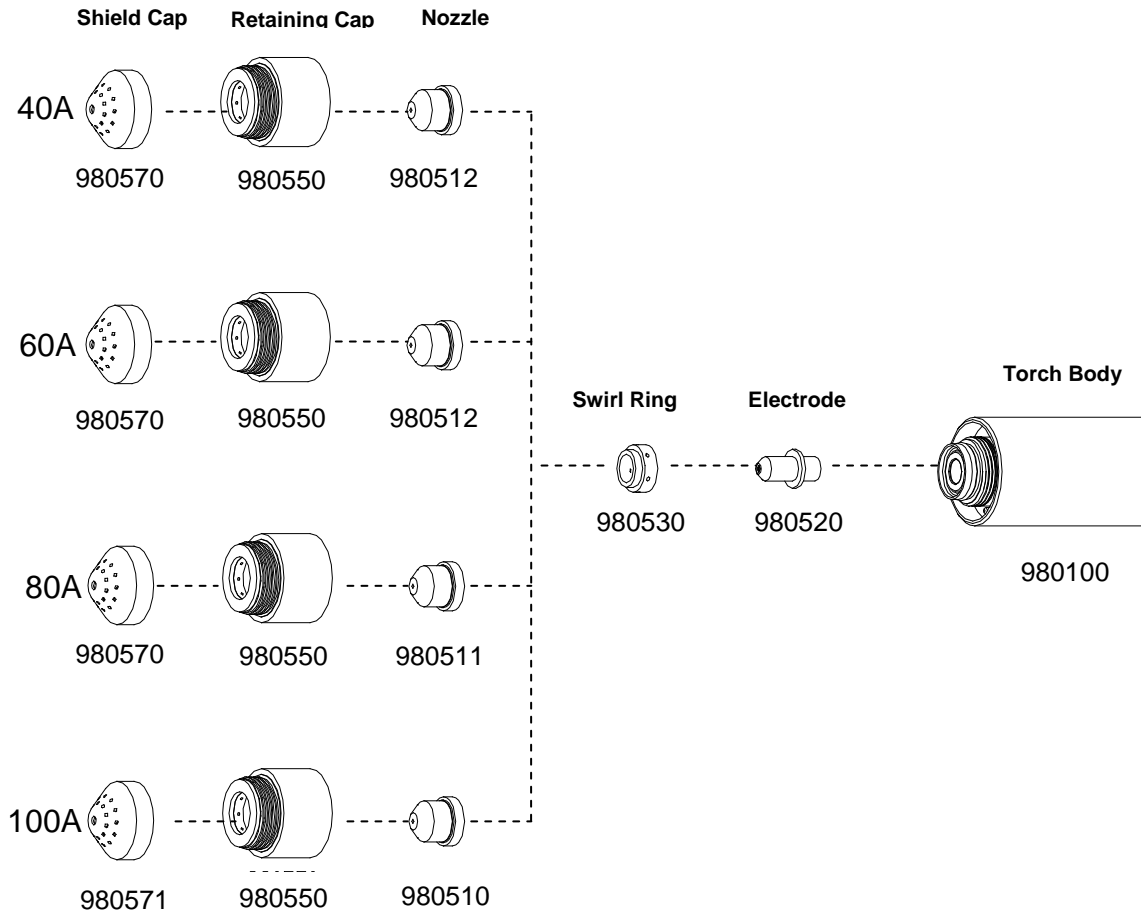

### CTP Retaining Cap

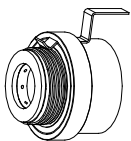

980560

Use CTP Retaining Cap with appropriate torch height control system.

This information is subject to the controls of the Export Administration Regulations [EAR]. This information shall not be provided to non-U.S. persons or transferred by any means to any location outside the United States contrary to the requirements of the EAR.

## Installing the Mechanized Torch Consumables

To install the torch parts, perform the following steps:

*Note: Do not over tighten the consumables!*

*Only tighten until the parts are seated properly.*

1. Inspect the threads on the torch body and copper retaining cap and clean as necessary.
2. Thread the shield cap (5) onto the retaining cap assembly. (4)
3. Place the nozzle (3) into the retaining cap/shield cap assembly.
4. Place the electrode (1) into the swirl ring. (2)
5. Insert the electrode/swirl ring assembly into the nozzle/ retaining cap assembly until it is seated properly

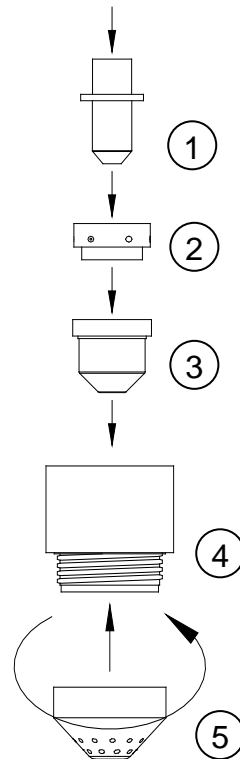

6. Thread the brass retaining cap assembly (6) onto the body.

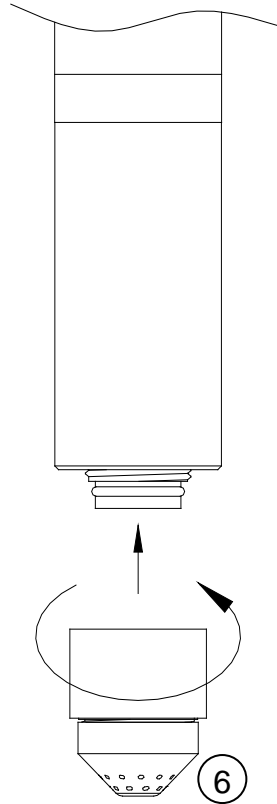

***Note: The Mechanized torch is equipped with a safety switch that detects when the consumables are installed. The consumables must be installed properly in order to operate the mechanized torch***

## Removing the Torch Consumables

To remove the torch consumables, perform the following steps:

1. Remove the retaining cap from the torch.
2. Remove the nozzle from the retaining cap.
3. Separate the shield cap from retaining cap.
4. Remove the electrode from the torch body. Pull straight down on the electrode to aid in removal.
5. Remove the swirl ring from the electrode.

***(Note: the swirl ring may come out with the retaining cap)***



## WARNING

Contaminants such as dirt, metallic dust, oil and moisture present on the surface of the electrode and/or torch body can cause electrical arcing between these components and ultimately result in failure of the torch and consumables. In order to avoid damaging the torch and/or consumables, adhere to the following guidelines:

1. Ensure that the air supplied to the torch does not contain contaminants such as debris, moisture and oil.
2. Ensure that the torch cathode body and electrode body are clean prior to assembling the consumables into the torch. Wipe away any contaminants with a dry, lint free cloth.
3. Be sure that the consumables are properly tightened when installing them into the torch to ensure that there is no gap between the electrode body and cathode body. Check the installation of the consumables before the start of each work shift and frequently during each work shift to ensure that the parts have not become loose as a result of normal operation.
4. Inspect the surfaces of the cathode body and electrode body to ensure no contaminants have collected during operation. (Reference Figure Below)

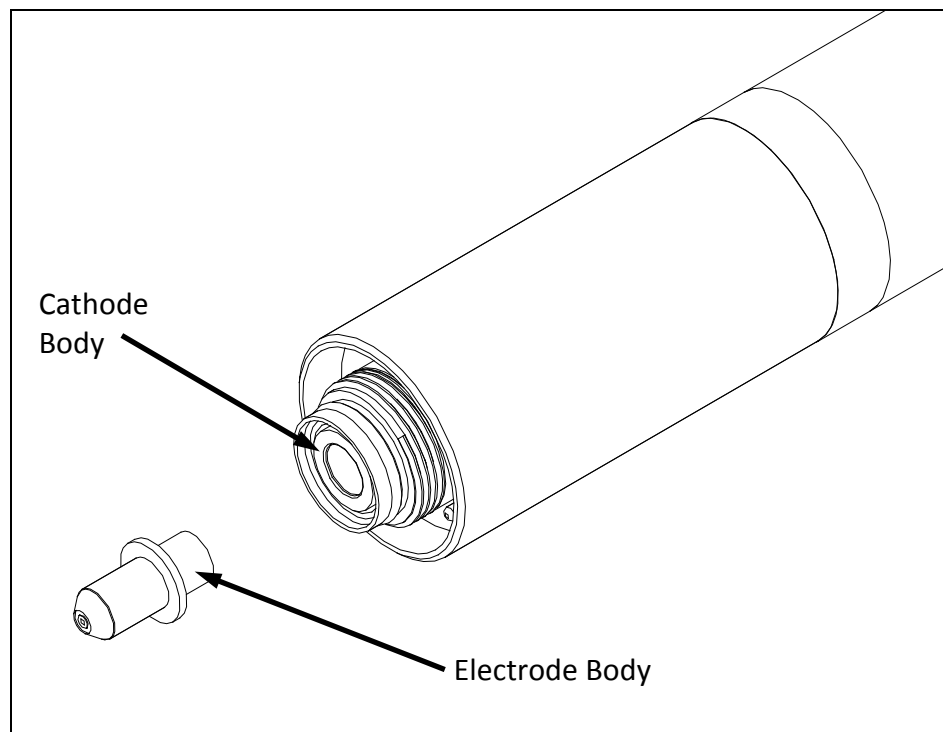

This information is subject to the controls of the Export Administration Regulations [EAR]. This information shall not be provided to non-U.S. persons or transferred by any means to any location outside the United States contrary to the requirements of the EAR.

## Making a Cut or Mark

### Setting up a Cut

Use the following procedure to make a cut with the Dagger 100.

1. Using the charts in this section, determine the proper torch parts and cutting conditions for the material being cut.
2. Install the proper consumables into the torch.
3. Turn the power switch to the **ON** position to apply power to the Dagger 100. The System Status light on the front panel should illuminate.
4. Place the Set/run switch in the set position and adjust the regulator pressure to 90 psi while gas is flowing through the torch. Return the Gas switch to the Run position.
5. Set the Current thumbwheel according to the cutting chart in this section.
6. Set the Mode Switch to the proper mode, as previously described.
7. The cutting operation is initiated after a start signal is received. The arc should establish approximately 2 seconds after application of the start command. Throughout the cut, the red D.C. Power light on the front panel should be illuminated to indicate that current is flowing through the torch. The cutting operation is terminated when the start signal is removed. At the completion of a cut, gas flow through the torch will continue for approximately 20 seconds.

When cutting expanded metal, the duration and or duty cycle for cutting may be limited depending upon the mesh opening, width of the web and travel speeds. The table below gives approximate duty cycles based on duration of cut. The maximum current for expanded metal cutting is 80 amps.

Duration of Cut	Duty Cycle
30 sec	70%
60 sec	60%
90 sec	40%
120 sec	15%

An adaptive post flow is used for expanded metal cutting which will extend the gas flow though the torch longer than 20 seconds after cutting based on the time of the cut and pilot arc duty.

## Cut Quality

Before the optimum cutting condition can be achieved on a particular material type and thickness, the machine operator must have a thorough understanding of the cutting characteristics of the Dagger100 system. When the cut quality is not satisfactory, the cutting speed, torch height, or gas pressures may need to be adjusted in small increments until the proper cutting condition is obtained. The following guidelines should be useful in determining which cutting parameter to adjust.

***Before making any parameter changes, verify that the torch is square to the work piece. Also, it is essential to have the correct torch parts in place and to ensure that they are in good condition. Check the electrode for excessive wear and the nozzle and shield cap orifices for roundness. Also, check the parts for any dents or distortions. Irregularities in the torch parts can cause cut quality problems.***

1. A positive cut angle (top dimension of piece smaller than the bottom dimension) usually occurs when the torch standoff distance is too high, when cutting too fast, or when excessive power is used to cut a given plate thickness.
2. A negative cut angle (top dimension of piece larger than the bottom dimension) usually occurs when the torch standoff distance is too low or when the cutting speed is too slow.
3. Top dross usually occurs when the torch standoff distance is too high.
4. Bottom dross usually occurs when the cutting speed is either too slow (slow-speed dross) or too fast (high-speed dross). Low-speed dross is easily removed, while high-speed dross usually requires grinding or chipping off. Bottom dross also occurs more frequently as the metal heats up. As more pieces are cut out of a particular plate, the more likely they are to form dross.
5. Note that different material compositions have an effect on dross formation.
6. If the material is not being completely severed, the likely causes are that the cutting current is too low, the travel speed is too high, the gas pressures are incorrect, the incorrect gas types are selected, the incorrect consumables are installed in the torch, or the consumables are worn.

## Inspection of Consumable Parts

When the cut quality is not satisfactory, use the following guidelines for determining which consumable parts need to be changed. Inspect all parts for dirt, debris, and excess o-ring lubricant and clean as necessary.

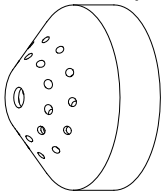
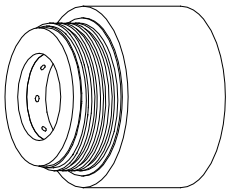
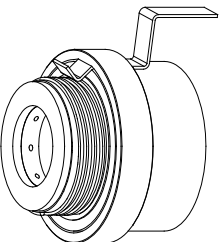
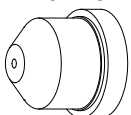
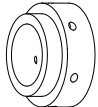
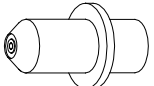
<b><u>Part</u></b>	<b><u>Inspect For</u></b>	<b><u>Corrective Action</u></b>
<b>Shield Cap</b> 	Center hole out of round Dents, Scratches	Replace shield cap Replace shield cap
<b>Retaining Cap</b> 		
<b>CTP Retaining Cap</b> 	Center hole out of round Dents, cracks	Replace retaining cap Replace retaining cap
<b>Nozzle</b> 	Center hole out of round Erosion or arcing	Replace nozzle Replace nozzle
<b>Swirl Ring</b> 	Damage Clogged holes	Replace swirl ring Blow out with compressed air. Replace swirl ring if clogs can't be removed
<b>Electrode</b> 	Pit depth Erosion or arcing	Replace electrode if center pit depth is greater than .040" (1 mm) Replace electrode

This information is subject to the controls of the Export Administration Regulations [EAR]. This information shall not be provided to non-U.S. persons or transferred by any means to any location outside the United States contrary to the requirements of the EAR.

---

## Cutting Charts

The cutting charts shown on the following pages are intended to give the operator the best starting point to use when making a cut on a particular material type and thickness. Small adjustments may have to be made to achieve the best cut. Also, remember that the arc voltage must be increased as the electrode wears in order to maintain the correct cutting height.

### Cutting Chart Index

Current	Page
40Amps	4-12
60 Amps	4-13
80 Amps	4-14
100 Amps	4-15

### 40 Amp mechanized shielded consumables

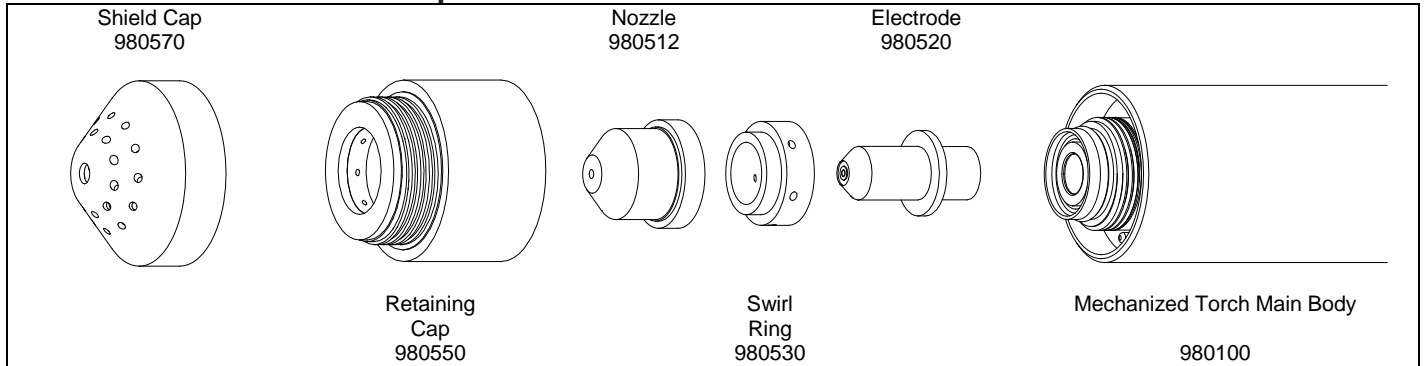

#### Mild Steel

Material Thickness			Arc Current	Arc Voltage	Optimum Travel Speed		Maximum Travel Speed		Cutting Height		Pierce Height		Pierce Time	Kerf Width	
ga	in	mm	amp	volts	ipm	mm/min	ipm	mm/min	in	mm	in	mm	ms	in	mm
18	.048	1.3	40	130	350	8890	550	13970	.100	2.5	.100	2.5	150	.060	1.5
16	.060	1.5			258	6553	425	10795							
14	.075	1.9			225	5715	370	9398							
10	.135	3.4		140	105	2667	155	3937	.125	3.2	.125	3.2	250	.070	1.8
-	3/16	4.8		145	65	1651	86	2184	.150	3.8	.150	3.8	600		
-	1/4	6.4			50	1270	60	1524					1200		

#### Stainless Steel

Material Thickness			Arc Current	Arc Voltage	Optimum Travel Speed		Maximum Travel Speed		Cutting Height		Pierce Height		Pierce Time	Kerf Width	
ga	in	mm	amp	volts	ipm	mm/min	ipm	mm/min	in	mm	in	mm	ms	in	mm
18	.048	1.3	40	130	335	8509	500	13970	.100	2.5	.125	3.2	300	.050	1.3
16	.060	1.5		132	245	6223	365	9271							
14	.075	1.9		134	145	3683	216	5486							
10	.135	3.4		138	70	1778	110	2794	.115	2.9	.150	3.8	500	.065	1.7
-	3/16	4.8		142	44	1118	64	1626					1200		
-	1/4	6.4		148	31	787	45	1143							

#### Aluminum

Material Thickness			Arc Current	Arc Voltage	Optimum Travel Speed		Maximum Travel Speed		Cutting Height		Pierce Height		Pierce Time	Kerf Width	
ga	in	mm	amp	volts	ipm	mm/min	ipm	mm/min	in	mm	in	mm	ms	in	mm
16	1/16	1.6	40	135	325	8255	433	10998	.090	2.3	.115	2.9	200	.050	1.3
14	3/32	2.3			215	5461	286	7264					300		
-	1/8	3.2			135	3429	180	4572	.100	2.5	.125	3.2	300	.060	1.5
-	1/4	6.4			143	45	1143	70	1778	.115	2.9	.150	3.8	1200	.065

#### Marking

Arc Current	Arc Voltage	Optimum Travel Speed		Marking Height		Initial Height		Pierce Time
amps	volts	ipm	mm/min	in	mm	in	mm	ms
12	160	250	6350	.100	2.5	.100	2.5	0

This information is subject to the controls of the Export Administration Regulations [EAR]. This information shall not be provided to non-U.S. persons or transferred by any means to any location outside the United States contrary to the requirements of the EAR.

### 60 Amp mechanized shielded consumables

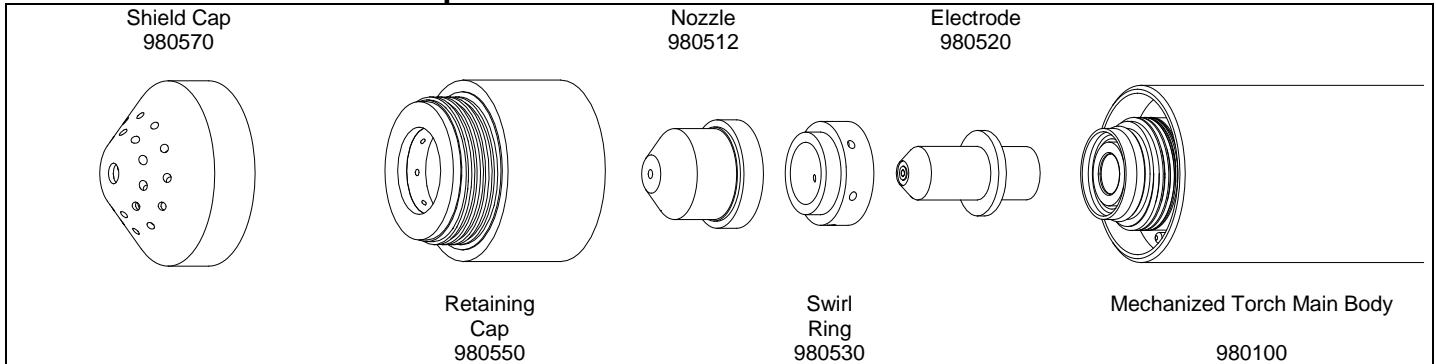

#### Mild Steel

Material Thickness			Arc Current	Arc Voltage	Optimum Travel Speed		Maximum Travel Speed		Cutting Height		Pierce Height		Pierce Time	Kerf Width		
ga	in	mm	amp	volts	ipm	mm/min	ipm	mm/min	in	mm	in	mm	ms	in	mm	
-	1/8	3.2	60	120	220	5588	271	6883	.063	1.6	.150	3.8	200	.068	1.7	
10	.135	3.4			215	5588	265	6731								
-	3/16	4.7		125	130	3300	170	4318	.080	2.0	.200	5.1	300	.075	1.9	
-	1/4	6.4		135	90	2286	118	2997	.128	3.3	.225	5.7	400	1000	.095	2.4
-	3/8	9.5			48	1219	60	1524			.250	6.4				
-	1/2*	12.7		147	30	762	38	965	.125	3.2	.200	5.1	1000	.115	2.9	
-	3/4*	19.1		152	12	305	20	508	.140	3.6						

#### Stainless Steel

Material Thickness			Arc Current	Arc Voltage	Optimum Travel Speed		Maximum Travel Speed		Cutting Height		Pierce Height		Pierce Time	Kerf Width	
ga	in	mm	amp	volts	ipm	mm/min	ipm	mm/min	in	mm	in	mm	ms	in	mm
16	.060	1.5	60	128	406	10312	625	15875	.100	2.5	.200	5.1	300	.070	1.8
10	.135	3.4		130	159	4039	235	5969	.100	2.5			400		
-	1/4	6.4		140	72	1829	100	2540	.115	2.9			800		
-	3/8	9.5		143	35	889	46	1168	.115	2.9	1000	.080	2.0		
-	1/2*	12.7		146	23	584	29	737	.125	3.2				.090	2.3
-	3/4*	19.1		153	12	305	15	381	.140	3.6				.105	2.7

#### Aluminum

Material Thickness			Arc Current	Arc Voltage	Optimum Travel Speed		Maximum Travel Speed		Cutting Height		Pierce Height		Pierce Time	Kerf Width	
ga	in	mm	amp	volts	ipm	mm/min	ipm	mm/min	in	mm	in	mm	ms	in	mm
-	1/16	1.6	60	128	433	10998	566	14376	.100	2.5	.200	5.1	300	.070	1.8
-	1/8	3.2		130	260	6604	340	8636							
-	1/4	6.4		136	95	2413	135	3429	.100	2.5			400	.075	1.9
-	3/8	9.5		143	50	1270	75	1905	.115	2.9	1000	.080	2.0		
-	1/2*	12.7		151	30	762	50	1270							
-	5/8*	19.1		155	21	533	31	787	.125	3.2				.085	2.2
															.095

\*Edge Start

#### Marking

Arc Current	Arc Voltage	Optimum Travel Speed		Marking Height		Initial Height		Pierce Time
amps	volts	ipm	mm/min	in	mm	in	mm	ms
12	160	250	6350	.100	2.5	.100	2.5	0

This information is subject to the controls of the Export Administration Regulations [EAR]. This information shall not be provided to non-U.S. persons or transferred by any means to any location outside the United States contrary to the requirements of the EAR.

**80 Amps – mechanized shielded consumables**

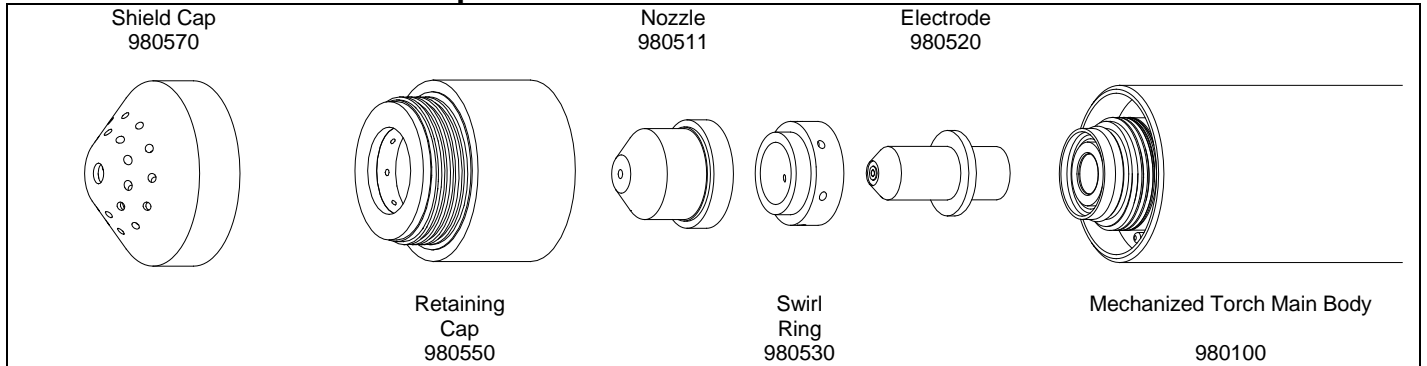

**Mild Steel**

Material Thickness		Arc Current	Arc Voltage	Optimum Travel Speed		Maximum Travel Speed		Cutting Height		Pierce Height		Pierce Time	Kerf Width	
in	mm	amp	volts	ipm	mm/min	ipm	mm/min	in	mm	in	mm	ms	in	mm
3/16	4.8	80	125	150	3809	230	5842	.100	2.5	.200	5.1	200	.080	2.0
1/4	6.4		130	110	2793	165	4191	.125	3.2	.225	5.7	300	.085	2.2
3/8	9.5		130	65	1651	98	2489	.145	3.6	.250	6.4	400	.098	2.5
1/2	12.7		135	40	1016	65	1651	.185	4.7	.300	7.6	1200	.115	2.9
3/4*	19.1		145	23	584	35	889	.170	4.3	.200	5.1	1000		
1*	25.4		164	10	254	17	432						.135	3.4

**Stainless Steel**

Material Thickness		Arc Current	Arc Voltage	Optimum Travel Speed		Maximum Travel Speed		Cutting Height		Pierce Height		Pierce Time	Kerf Width			
in	mm	amp	volts	ipm	mm/min	ipm	mm/min	in	mm	in	mm	ms	in	mm		
3/16	4.8	80	128	145	3683	220	5588	.100	2.5	.200	5.1	400	.070	1.8		
1/4	6.4		128	105	2667	156	3962					600				
3/8	9.5		132	54	1397	80	2032	.150	3.8	.225	5.7	800				
1/2	12.7		140	33	812	45	1143	.155	3.9	.300	7.6	1200				
3/4*	19.1		154	16	406	22	559	.160	4.1	.200	5.1	1000			.115	2.9
1*	25.4		160	9	229	12	305									

**Aluminum**

Material Thickness		Arc Current	Arc Voltage	Optimum Travel Speed		Maximum Travel Speed		Cutting Height		Pierce Height		Pierce Time	Kerf Width					
in	mm	amp	volts	ipm	mm/min	ipm	mm/min	in	mm	in	mm	ms	in	mm				
1/8	3.2	80	128	300	7620	455	11,557	.100	2.5	.200	5.1	400	.080	2.0				
1/4	6.4		137	115	2921	180	4572					600						
3/8	9.5		143	65	1651	115	2921					.225			5.7	800	.095	2.4
1/2	12.7		147	40	1016	72	1829			.300	7.6	1200			.115	2.9		
3/4*	19.1		154	20	508	35	889			.115	2.9	.200			5.1	1000	.120	3.1

\*Edge Start

**Marking**

Arc Current	Arc Voltage	Optimum Travel Speed		Marking Height		Initial Height		Pierce Time
amps	volts	ipm	mm/min	in	mm	in	mm	ms
15	155	250	6350	.100	2.5	.100	2.5	0

This information is subject to the controls of the Export Administration Regulations [EAR]. This information shall not be provided to non-U.S. persons or transferred by any means to any location outside the United States contrary to the requirements of the EAR.

**100 Amps – mechanized shielded consumables**

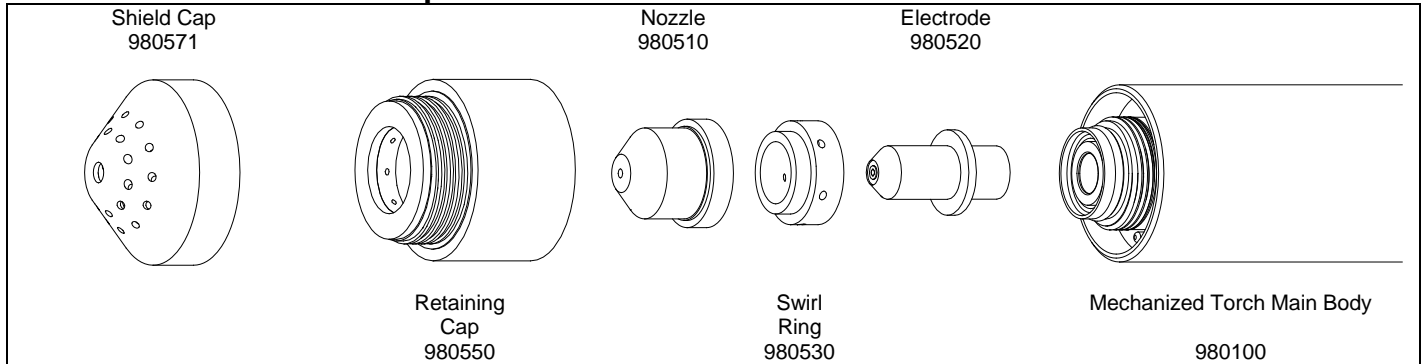

**Mild Steel**

Material Thickness		Arc Current	Arc Voltage	Optimum Travel Speed		Maximum Travel Speed		Cutting Height		Pierce Height		Pierce Time	Kerf Width	
in	mm	amp	volts	ipm	mm/min	ipm	mm/min	in	mm	in	mm	ms	in	mm
1/4	6.4	100	120	140	3556	208	5283	.090	2.3	.200	5.1	400	.085	2.2
3/8	9.5		130	82	2082	112	2845	.136	3.5	.250	6.5	600	.100	2.5
1/2	12.7			60	1524	81	2057			.300	7.6	800		
5/8	15.9		140	40	1016	52	1321	.150	3.8	.325	8.3	1200	.125	3.2
3/4	19.1		145	30	762	38	965	.155	3.9	.400	9.0	2200		
1*	25.4		151	18	457	23	584	.160	4.1	.200	5.1	1000	.155	3.9
1 1/4*	32		165	10	254	16	406	.165	4.2					

**Stainless Steel**

Material Thickness		Arc Current	Arc Voltage	Optimum Travel Speed		Maximum Travel Speed		Cutting Height		Pierce Height		Pierce Time	Kerf Width	
in	mm	amp	volts	ipm	mm/min	ipm	mm/min	in	mm	in	mm	ms	in	mm
1/4	6.4	100	130	150	3810	235	5969	.115	2.9	.200	5.1	400	.090	2.3
3/8	9.5		135	80	2032	110	2794	.120	3.1	.250	6.5	600	.090	2.3
1/2	12.7		140	52	1321	72	1829	.120		.300	7.6	1500	.100	2.5
5/8	15.9		141	32	864	48	1219	.125	3.2	.400	9.0	2200	.105	2.7
3/4*	19.0		143	25	635	36	914	.130	3.3	.200	5.1	1000		
1*	25.4		152	15	381	21	533	.150	3.8				.120	3.1

**Aluminum**

Material Thickness		Arc Current	Arc Voltage	Optimum Travel Speed		Maximum Travel Speed		Cutting Height		Pierce Height		Pierce Time	Kerf Width	
in	mm	amp	volts	ipm	mm/min	ipm	mm/min	in	mm	in	mm	ms	in	mm
1/4	6.4	100	130	165	4191	250	6349	.100	2.5	.200	5.1	400	.085	2.2
3/8	9.5		140	92	2337	140	3556	.115	2.9	.250	6.5	600	.100	2.5
1/2	12.7		145	70	1778	105	2667	.145	3.7	.300	7.6	1500		
5/8	15.9		150	48	1219	76	1930	.155	3.9	.400	9.0	2200	.110	2.8
3/4*	19.0		152	33	838	55	1397	.160	4.1	.200	5.1	1000		
1*	25.4		162	20	508	30	761	.160					.140	3.6

\*Edge Start

**Marking**

Arc Current	Arc Voltage	Optimum Travel Speed		Marking Height		Initial Height		Pierce Time
amps	volts	ipm	mm/min	in	mm	in	mm	ms
15	155	250	6350	.100	2.5	.100	2.5	0

This information is subject to the controls of the Export Administration Regulations [EAR]. This information shall not be provided to non-U.S. persons or transferred by any means to any location outside the United States contrary to the requirements of the EAR.

# Section 5 Maintenance and Troubleshooting

**Warning:** *Only qualified maintenance personnel should perform maintenance on the Dagger100 system. The system utilizes potentially fatal A.C. and D.C. voltages. All maintenance should be performed with safety in mind. Be aware that the large electrolytic capacitors inside the power supply store large amounts of energy even after power has been removed from the system. Wait at least five minutes after turning off power before touching any of the internal components.*

## Daily Procedures

### Dagger100 Power Supply

1. Verify that the green status light is illuminated when primary power is applied to the system.
2. Place the Gas switch in the Set position and verify that air is flowing through the torch.
3. With the Set/Run switch in the Set position, adjust the regulator on the rear panel of the Dagger100 to 90 psi. Return the Set/Run switch to the Run position.
4. Raise the mechanized torch 2 inches above the workpiece. Apply a start signal to the Dagger100 using the CNC control. The pilot arc should be established in approximately 2 seconds. The arc should extend approximately 1 inch from the nozzle

**\*\* WARNING \*\***

***Remove primary power from the system  
before performing the following procedures***

### Dagger100 Mechanized Torch Assembly

1. Check the outer cover of the torch lead for nicks or cuts. If the outer cover is damaged, make sure the underlying wires are in good working condition. If there is any damage to the insulation of the underlying wires, the torch lead must be replaced.
2. Remove all consumables from the torch and verify that the anode-cathode insulator (brown plastic) is in good condition and has no signs of arcing.
3. Check all consumables and discard any damaged items.
4. Verify that the electrode seat is clean to ensure proper electrical contact.
5. Reassemble the electrode, swirl ring and nozzle and install them in the torch.
6. Make sure that the retaining cap is hand tight and all parts are seated properly.

## Monthly Procedures

**Note:** At minimum, these checks should be performed on a monthly basis. In excessively dirty environments or in heavy usage situations, the checks should be performed more frequently.

### Power Supply

1. Remove the left and right panels of the power supply.
2. Using clean, dry, compressed air, blow out all accumulated dust inside the power supply, including dust on p.c. boards and fans. Be sure to blow out the fan at the rear of the unit. In an excessively dirty environment, blow out the unit on a weekly basis.
3. Verify that all torch lead and work ground connections are secure and free from corrosion.
4. Verify that the primary three phase A.C. voltage connections are tight
5. Verify that all p.c. board connectors are installed securely.
6. Verify that the rear panel cable connectors are installed securely.

### Mechanized Torch Assembly

1. Verify that the torch lead connection at the power supply is tight and that there are no leaks. **Only tighten the enough to provide a gas tight seal. The connections are subject to damage if over tightened.**
2. Inspect the torch leads for nicks or cuts and replace if necessary.
3. Remove the torch handle and verify that the connections at the rear of the torch are tightened securely. **Only tighten the fitting enough to make the gas seal. The fittings are subject to damage if over tightened.**

### Work Ground

1. Verify that the work ground lead is securely fastened to the star ground on the cutting table, and that the connection point is free from corrosion. Use a wire brush to clean the connection point if necessary.

### Gas Supply

1. Check for signs of contamination in the gas supply lines.
2. Drain Filter Bowl as needed.
3. Listen for gas leaks in the supply lines and in the internal plumbing system. Tighten any connections that are leaking. Leaks in the supply can cause poor cut quality, as well as torch overheating.
4. Replace the Regulator Filter Element as necessary. A good rule to follow is to replace the filter element whenever the pressure drop across a filter at rated flow is approximately 10 psi. To replace the element:
  - Remove the bowl from the filter body.
  - Remove the element from the filter body. The plastic ring and/or o-ring may come off with the element.
  - Pull down on the element to separate the plastic ring and the o-ring from the element.
  - Discard the used element.
  - Place the new element inside the plastic ring and the o-ring.
  - Thread the element onto the filter body.
  - Thread the bowl onto the filter body.

This information is subject to the controls of the Export Administration Regulations [EAR]. This information shall not be provided to non-U.S. persons or transferred by any means to any location outside the United States contrary to the requirements of the EAR.

## Trouble Shooting

The front panel red Fault Status indicator will display fault information useful in troubleshooting. The power supply microprocessor displays an error code by blinking the Fault Status indicator on and off to indicate which error has occurred. The number of blinks will indicate the type of error as outlined in the chart below. The chart lists the errors and possible solutions.

<u>Number of Blinks</u>	<u>Error</u>	<u>Possible Solution</u>
0*	<ul style="list-style-type: none"> <li>Torch consumables are not installed or installed incorrectly</li> </ul>	<ul style="list-style-type: none"> <li>Remove power and check the torch consumables.</li> </ul>
1	<ul style="list-style-type: none"> <li>Transformer over temperature</li> </ul>	<ul style="list-style-type: none"> <li>Make sure ambient temperature does not exceed rated temperature</li> <li>Verify cooling fans are operating properly and are not clogged or air flow blocked</li> </ul>
2	<ul style="list-style-type: none"> <li>Heatsink over temperature</li> </ul>	<ul style="list-style-type: none"> <li>Make sure ambient temperature does not exceed rated temperature</li> <li>Verify cooling fans are operating properly and are not clogged or air flow blocked</li> </ul>
3	<ul style="list-style-type: none"> <li>Low gas pressure</li> </ul>	<ul style="list-style-type: none"> <li>Check gas supply pressure</li> <li>Verify there are no restrictions in the supply gas hose</li> </ul>
4	<ul style="list-style-type: none"> <li>Over Current (output)</li> </ul>	<b>Contact KALIBURN technical support</b>
5	<ul style="list-style-type: none"> <li>Pilot arc not established</li> </ul>	<ul style="list-style-type: none"> <li>Check torch connections and consumables</li> </ul>
6	<ul style="list-style-type: none"> <li>Transferred arc not established</li> </ul>	<ul style="list-style-type: none"> <li>Check work ground for proper installation</li> <li>Check for adequate gas flow</li> <li>Check consumables</li> </ul>
7	<ul style="list-style-type: none"> <li>Output voltage below 30V</li> </ul>	<ul style="list-style-type: none"> <li>Check operating conditions – current, voltage, torch height</li> <li>Check consumables</li> <li><b>Contact KALIBURN technical support</b></li> </ul>
8	<ul style="list-style-type: none"> <li>Input voltage above 660V</li> </ul>	<ul style="list-style-type: none"> <li>Verify Input voltage</li> <li>Contact KALIBURN technical support</li> </ul>
9	<ul style="list-style-type: none"> <li>Loss of transferred arc</li> </ul>	<ul style="list-style-type: none"> <li>Torch retract before down slope completed</li> <li>Check work ground lead</li> <li>Check operating conditions</li> <li>Check consumables</li> </ul>
10	<ul style="list-style-type: none"> <li>Exceeded Pilot Arc duty</li> </ul>	<ul style="list-style-type: none"> <li>Reference operation section on expanded metal cutting</li> </ul>

\*The fault LED is illuminated with no blinks.

The following chart lists general troubleshooting guidelines for the Dagger100 system. Please contact KALIBURN technical support for any issues not covered in this section. Before any tests are performed, make sure that all system fuses are good.

<b>Problem</b>	<b>Possible Causes</b>	<b>Possible Solutions</b>
<b>Front panel red D.C. power light will not illuminate</b>	<ul style="list-style-type: none"> <li>• Regulator pressure too low</li> <li>• Torch consumables not installed correctly or damaged</li> <li>• Red D.C. Power light or associated wiring may be bad.</li> </ul>	<ul style="list-style-type: none"> <li>• Check gas pressure/ adjust pressure if needed (see section 2 Gas Supply Requirements)</li> <li>• Check torch consumables, replace/ install correctly if needed (see installing torch consumable section 4)</li> <li>• Check the D.C. power light and associated wiring/replace if needed (see system Schematic)</li> </ul>
<b>Front panel green Gas Pressure Indicator will not illuminate</b>	<ul style="list-style-type: none"> <li>• Supply gas pressure low.</li> <li>• Faulty Green Gas Pressure light or associated wiring.</li> <li>• Faulty pressure switch or associated wiring.</li> </ul>	<ul style="list-style-type: none"> <li>• Check the gas supply pressure and adjust / replace if pressure low.</li> <li>• Check electrical connections to Gas Pressure light / replace if needed (see system schematic)</li> <li>• Check pressure switch and/or wiring</li> <li>• Contact KALIBURN technical support</li> </ul>
<b>The arc will not transfer to the work piece</b>	<ul style="list-style-type: none"> <li>• Incorrect, damaged, or worn consumables.</li> <li>• Loose work ground connection.</li> <li>• Pierce height too high.</li> <li>• There is not adequate gas flow</li> </ul>	<ul style="list-style-type: none"> <li>• Check torch consumables, replace/ install correctly if needed (see installing torch consumable section 4)</li> <li>• Check all connections on the work ground lead. Verify that the connections are tight and free from corrosion. If necessary, use a wire brush to clean the connections. (See section 3 for work ground lead installation)</li> <li>• Check the torch work standoff initial height</li> <li>• Check gas flow/ adjust if needed (see section 2 Gas Supply Requirements)</li> </ul>
<b>Torch will not ignite</b>	<ul style="list-style-type: none"> <li>• Consumables worn</li> <li>• Torch connection not tight</li> <li>• Torch leads are damaged</li> </ul>	<ul style="list-style-type: none"> <li>• Check torch consumables, replace/ install correctly if needed (see installing torch consumable section 4).</li> <li>• Verify that torch connection to the power supply is tight. Tighten if needed. (See section 3 quick disconnect torch lead)</li> <li>• Verify that all torch lead fittings are secure. Replace the torch leads if there are any visible signs of damage (See section 3 for torch to torch lead connections)</li> </ul>

This information is subject to the controls of the Export Administration Regulations [EAR]. This information shall not be provided to non-U.S. persons or transferred by any means to any location outside the United States contrary to the requirements of the EAR.

<p><b>Poor cut quality</b></p>	<ul style="list-style-type: none"> <li>• Consumables worn or incorrect consumables in torch.</li> <li>• Gas pressure not adjusted correctly</li> <li>• Incorrect cutting conditions (current, speed, torch height, mode of operation, etc.).</li> <li>• Workpiece not grounded to the cutting table.</li> <li>• Gas supply contaminated.</li> </ul>	<ul style="list-style-type: none"> <li>• Check torch consumables, replace/ install correctly if needed (see installing torch consumable section 4)</li> <li>• Check gas pressure/ adjust pressure if needed (see section 2 Gas Supply Requirements)</li> <li>• Check Cutting conditions/ See Section 4 for cutting conditions.</li> <li>• Check cutting table/ Replace the table slats if needed</li> <li>• Check the filter/ regulator. Install/replace filters or drain filter bowl if needed.</li> </ul>
--------------------------------	-----------------------------------------------------------------------------------------------------------------------------------------------------------------------------------------------------------------------------------------------------------------------------------------------------------------------------------------------------	-------------------------------------------------------------------------------------------------------------------------------------------------------------------------------------------------------------------------------------------------------------------------------------------------------------------------------------------------------------------------------------------------------------------------------------------------------------------------------------------------------------

This information is subject to the controls of the Export Administration Regulations [EAR]. This information shall not be provided to non-U.S. persons or transferred by any means to any location outside the United States contrary to the requirements of the EAR.

## Section 6 Parts List

### Power Supply

(See *Figures Below*)

<u>Item Number</u>	<u>Part Number</u>	<u>Quantity</u>	<u>Description</u>
1	705011	1	Pilot Arc transistor IGBT
2	980610	1	Optional Height Control Voltage Divider P.C. Board
3	980009	2	Solenoid Valve, 3 way
4	708205	1	Pressure Switch
5	740120	1	Air Regulator with Filter
6	740123	1	Air Regulator Filter
7	980500	2	Fan
8	980200	1	Impulse Starting P.C. Board
9	708203	1	Disconnect Switch
10	709298	1	Fuse
11	850100	1	Sequencer P.C. Board
12	277070	1	Current Thumbwheel Assembly
13	702086	1	Line Filter (CE Model Only)

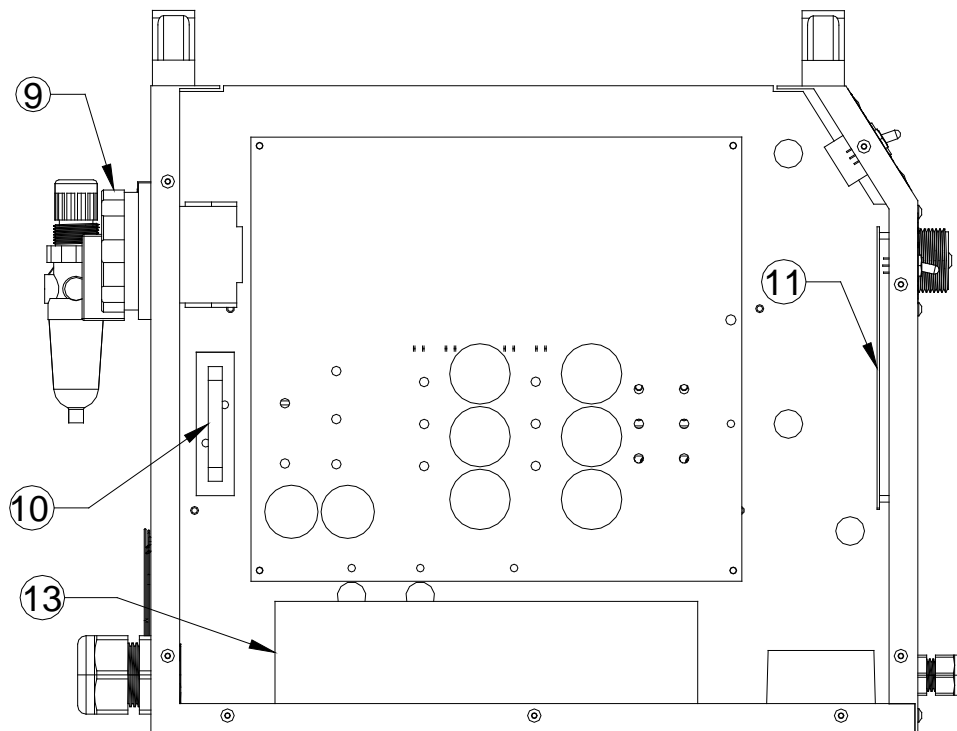
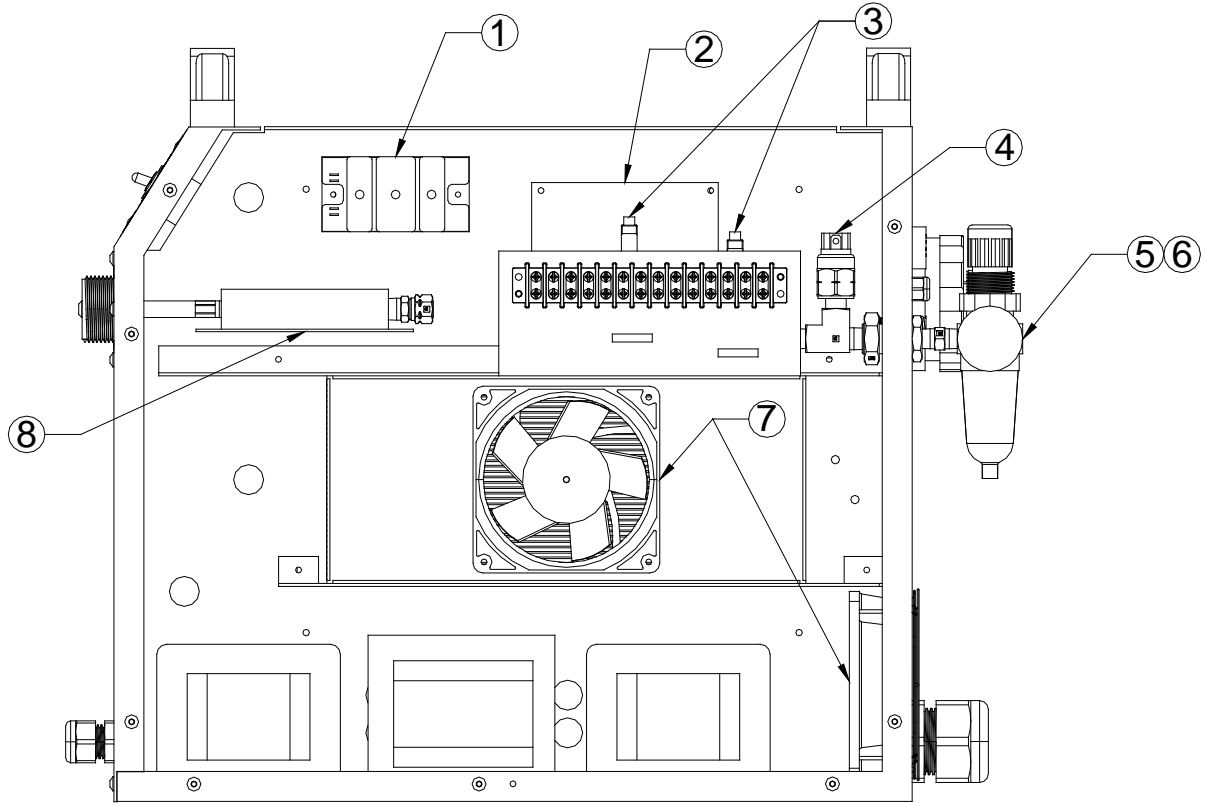

This information is subject to the controls of the Export Administration Regulations [EAR]. This information shall not be provided to non-U.S. persons or transferred by any means to any location outside the United States contrary to the requirements of the EAR.

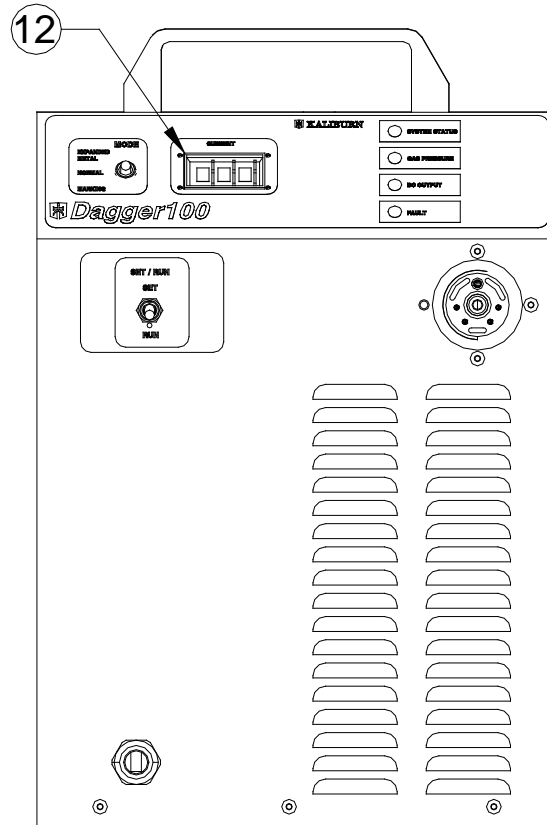

This information is subject to the controls of the Export Administration Regulations [EAR]. This information shall not be provided to non-U.S. persons or transferred by any means to any location outside the United States contrary to the requirements of the EAR.

## Mechanized Torch Assembly

<u>Item Number</u>	<u>Part Number</u>	<u>Quantity</u>	<u>Description</u>
1	980100	1	Mechanized torch main body
2	980138	1	Mechanized torch handle

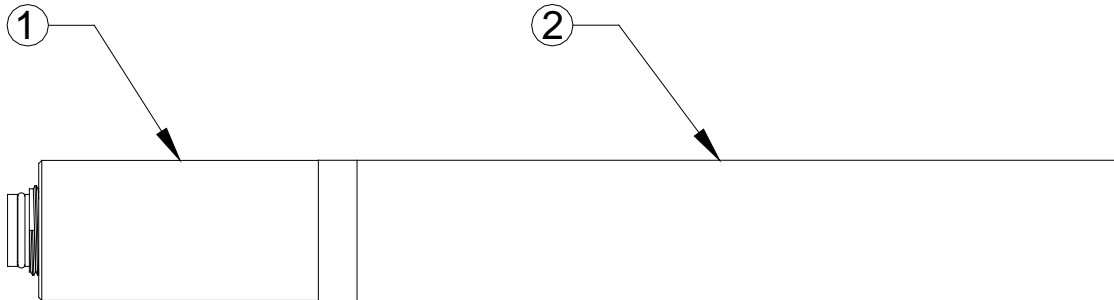

## Leads Assemblies

<u>Part Number</u>	<u>Length</u>
980190-25	25 ft. (3.0 m)
980190-35	35 ft. (4.6 m)
980190-50	50 ft. (6.1 m)

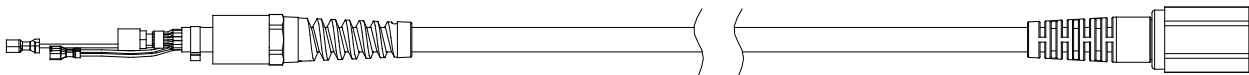

## CTP Leads Assemblies

<u>Part Number</u>	<u>Length</u>
980195-25	25 ft. (3.0 m)
980195-35	35 ft. (4.6 m)
980195-50	50 ft. (6.1 m)

This information is subject to the controls of the Export Administration Regulations [EAR]. This information shall not be provided to non-U.S. persons or transferred by any means to any location outside the United States contrary to the requirements of the EAR.

---

## Consumable Spare Parts Kit

<u>Part Number</u>	<u>Quantity</u>	<u>Description</u>
980520	12	Electrode
980510	2	100a Nozzle
980511	1	80a Nozzle
980512	2	60a / 40a Nozzle
980530	1	Swirl Ring
980550	1	Retaining Cap
980570	2	80a / 60a / 40a Shield Cap
980571	2	100a Shield Cap

---

# Appendix A Electromagnetic Compatibility (EMC)

## Background

The CE marked Dagger100 plasma cutting systems are manufactured to comply with the European standard EN 60974-10 (Electromagnetic compatibility (EMC) – Product standard for arc welding equipment). The system has been tested in accordance with CISPR 11, EMC classification – Group 2 ISM (Class A).

The limits used in this standard are based on practical experience. However, the ability of plasma cutting equipment to work in a compatible manner with other radio and electronic systems is greatly influenced by the manner in which it is installed and used. For this reason, it is important that the plasma cutting equipment be installed and used in accordance with the information below if electromagnetic compatibility is to be achieved.

Plasma cutting equipment is primarily intended for use in an industrial environment. There may be potential difficulties in ensuring electromagnetic compatibility in other environments.

## Installation and Use

The user is responsible for installing and using the plasma cutting equipment according to the manufacturer's instructions. If electromagnetic disturbances are detected then it shall be the responsibility of the user of the plasma cutting equipment to resolve the situation with the technical assistance of the manufacturer. In some cases this remedial action may be as simple as earthing the plasma cutting circuit, see Note. In other cases it could involve constructing an electromagnetic screen enclosing the plasma power source and the work, complete with associated input filters. In all cases, electromagnetic disturbances shall be reduced to the point where they are no longer troublesome.

Note: The plasma cutting circuit may or may not be earthed for safety reasons. Changing the earthing arrangements should only be authorized by a person who is competent to assess whether the changes will increase the risk of injury, e.g. by allowing parallel plasma cutting current return paths which may damage the earth circuits of other equipment. Further guidance is given in IEC 974-13 *Arc welding equipment – Installation and use*.

---

## Assessment of Area

Before installing plasma cutting equipment, the user shall make an assessment of potential electromagnetic problems in the surrounding area. The following shall be taken into account:

- a) other supply cables, control cables, signaling and telephone cables; above, below and adjacent to the plasma cutting equipment;
- b) radio and television transmitters and receivers;
- c) computer and other control equipment;
- d) safety critical equipment, e.g. guarding of industrial equipment;
- e) the health of the people around, e.g. the use of pacemakers and hearing aids;
- f) equipment used for calibration or measurement;
- g) the immunity of other equipment in the environment; the user shall ensure that other equipment being used in the environment is compatible; this may require additional protection measures;
- h) the time of day that plasma cutting or other activities are to be carried out.

The size of the surrounding area to be considered will depend on the structure of the building and other activities that are taking place. The surrounding area may extend beyond the boundaries of the premises.

## Methods of Reducing Emissions

### Mains Supply

Plasma cutting equipment should be connected to the mains supply according to the manufacturer's recommendations. If interference occurs, it may be necessary to take additional precautions such as filtering of the mains supply. Consideration should be given to shielding the supply cable of permanently installed plasma cutting equipment in metallic conduit or equivalent. Shielding should be electrically continuous throughout its length. The shielding should be connected to the plasma power source so that good electrical contact is maintained between the conduit and the plasma power source enclosure.

### Maintenance of the Plasma Cutting Equipment

The plasma cutting equipment should be routinely maintained according to the manufacturer's recommendations. All access and service doors and covers should be closed and properly fastened when the plasma cutting equipment is in operation. The plasma cutting equipment should not be modified in any way except for those changes and adjustments covered in the manufacturer's instructions. In particular, the spark gaps of arc striking and stabilizing devices should be adjusted and maintained according to the manufacturer's recommendations.

This information is subject to the controls of the Export Administration Regulations [EAR]. This information shall not be provided to non-U.S. persons or transferred by any means to any location outside the United States contrary to the requirements of the EAR.

**Plasma Cutting Cables**

The plasma cutting cables should be kept as short as possible and should be positioned close together, running at or close to the floor level.

**Equipotential Bonding**

Bonding of all metallic components in the plasma cutting installation and adjacent to it should be considered. However, metallic components bonded to the workpiece will increase the risk that the operator could receive a shock by touching these metallic components and the electrode at the same time. The operator should be insulated from all such bonded metallic components.

**Earthing of the Workpiece**

Where the workpiece is not bonded to earth for electrical safety, nor connected to earth because of its size and position, e.g. ship's hull or building steelwork, a connection bonding the workpiece to earth may reduce emissions in some, but not all instances. Care should be taken to prevent the earthing of the workpiece increasing the risk of injury to users, or damage to other electrical equipment. Where necessary, the connection of the workpiece to earth should be made by a direct connection to the workpiece, but in some countries where direct connection is not permitted, the bonding should be achieved by suitable capacitance, selected according to national regulations.

**Screening and Shielding**

Selective screening and shielding of other cables and equipment in the surrounding area may alleviate problems of interference. Screening of the entire welding installation may be considered for special applications.